

**verizon**<sup>v</sup>

**digital media  
services**

Copyright © 2017, Verizon Digital Media Services. All rights reserved.

# **Volicon Media Intelligence service**

**8.1 Admin Guide**

---

## Warranty and limitations

The information in this document is subject to change without notice and does not represent a commitment on the part of Verizon Digital Media Services' Volicon Media Intelligence service; it's not a binding contract. Volicon Media Intelligence service will not be held responsible for failures or errors in the text of the document, nor be liable for it in any claim from any third party. Documentation is provided "as is". All conditions, representations and warranties, expressed or implied, including any implied warranty of merchantability, fitness for a particular purpose or non-infringement, are disclaimed, except to the extent that such disclaimers are held to be legally invalid. This document contains proprietary information belonging to Volicon Media Intelligence service. Such information is supplied solely for assisting properly authorized users of Volicon Media Intelligence service systems. No part of its contents may be used for any other purpose or disclosed to any person or firm. No part or parts of this document shall be copied, used for commercial purposes or passed to any third party for any use, without approval from Volicon Media Intelligence service. The text and graphics are for the purpose of illustration and reference only. The information herein is subject to change without notice.

## Document Details

**Document name:**

Volicon Media Intelligence service  
8.1 Admin Guide

---

## Table of contents

<b>1</b>	<b>Introduction</b>	<b>7</b>
1.1	Purpose and scope	7
1.2	About the Volicon Media Intelligence service	7
1.3	Conventions used in this manual	8
1.4	Definitions and acronyms	9
<b>2</b>	<b>Volicon Media Intelligence services</b>	<b>12</b>
<b>3</b>	<b>Servers</b>	<b>13</b>
3.1	Server dimensions and power requirements	13
3.2	Mounting, power, basic connections	14
3.2.1	Power distribution	14
3.2.2	Total power	14
3.2.3	HVAC	14
3.2.4	STB shelves	15
3.2.5	Typical rack layout with set-top boxes	15
3.3	Server front panel indicators and controls	16
3.3.1	Power on and shut down	16
3.3.2	Server front panel indicators	17
3.3.3	Drive carrier indicators	18
3.3.4	Power supply indicator	19
3.4	Server rear panel connections	19
3.5	Capture cards	19
<b>4</b>	<b>Software installation</b>	<b>20</b>
4.1	Central and probe server operating systems	20
4.1.1	Additional Microsoft software	20
4.1.2	Third-party software	20
4.2	Client workstation	21
4.2.1	Client-side browsers	21
4.3	Initial Volicon Media Intelligence service deployment	21
4.4	Optional Volicon Media Intelligence service modules	21
4.5	Managing Volicon Media Intelligence service software updates	22
4.6	Upgrading from previous versions of Volicon Media Intelligence service	23
<b>5</b>	<b>Adding Volicon Media Intelligence service servers to your network</b>	<b>24</b>
5.1	IP port utilization	24
5.2	Network bandwidth	26
<b>6</b>	<b>Initial O/S level setup</b>	<b>27</b>
6.1	Active directory (AD) integration	27
6.1.1	Prerequisites	27
6.1.2	AD operation	27
6.2	Antivirus exclusion storage areas	28
6.3	Remote server access	29

6.3.1	Server-side Microsoft RDP .....	29
6.3.2	RDP client .....	30
6.3.3	Login .....	31
6.3.4	Terminate remote session .....	31
<b>7</b>	<b>RAID disk drive array .....</b>	<b>32</b>
7.1	RAID variants .....	32
7.2	RAID controllers.....	33
7.3	Accessing the RAID controller.....	33
7.4	Main megaRAID screen .....	35
7.4.1	Silencing RAID alarm .....	35
7.5	Email alerts.....	36
7.6	Hard disk drive (HDD) replacement .....	36
<b>8</b>	<b>Capture cards and breakout cables .....</b>	<b>37</b>
8.1	Blackmagic.....	38
8.1.1	Intensity PRO 4K.....	38
8.1.2	DeckLink Extreme 4K .....	39
8.1.3	DeckLink SDI 4K .....	41
8.1.4	DeckLink Studio 4K .....	41
8.1.5	DeckLink Duo .....	42
8.1.6	DeckLink Quad SDI .....	42
8.1.7	DeckLink Mini Recorder.....	43
8.1.8	DeckLink Mini Monitor .....	44
8.2	DekTec.....	44
8.2.1	DekTec DTA-2111 .....	44
8.2.2	DekTec DTA-2136.....	45
8.2.3	DekTec DTA-2137C .....	46
8.2.4	DekTec DTA-2145.....	46
8.3	Hauppauge .....	47
8.3.1	Hauppauge 01609 .....	47
8.3.2	Hauppauge HVR-2255 .....	48
8.4	Osprey .....	48
8.4.1	Osprey 260e.....	48
8.4.2	Osprey 460e.....	49
8.5	Set-top box interconnect.....	51
<b>9</b>	<b>What NOT to do on the server side .....</b>	<b>52</b>
<b>10</b>	<b>Volicon Media Intelligence service login .....</b>	<b>53</b>
10.1	Logging out.....	54
10.2	Internet Explorer settings .....	54
10.3	Non-IE browsers support, clientless mode.....	56
10.4	Volicon Media Intelligence service ActiveX media player.....	56
10.4.1	Installing the media player .....	56
10.4.2	Updating the media player.....	60
10.4.3	Removing the media player .....	60
10.5	Volicon Media Intelligence service welcome page.....	61

<b>11</b>	<b>Volicon Media Intelligence service web-based configuration</b>	<b>62</b>
11.1	System architecture	63
11.2	Configuration: Probe groups	64
11.2.1	Create a probe group	65
11.2.2	Rename a probe group	67
11.2.3	Delete a probe group	67
11.2.4	Adding a probe	67
11.2.5	Editing a probe	68
11.2.6	Creating and editing encoders	73
11.2.7	Adding an encoder	73
11.2.8	Encoder configuration	73
11.3	Configuration: Probe profiles	99
11.4	Configuration: Encoder profiles	99
11.5	Configuration: Manage streams	99
11.6	Settings: Central server	99
11.6.1	System	100
11.6.2	Settings: SNMP receivers	101
11.6.3	Settings: Channel set	102
11.6.4	Distribution profiles	103
11.6.5	Roles	107
11.6.6	Users	111
11.7	Active users	113
11.7.1	Force user logout	113
11.8	Preferences	113
11.8.1	Main	114
11.8.2	Passwords	115
11.9	System health	115
11.9.1	Alerts	116
11.9.2	User activity	116
11.9.3	Event viewer	117
11.10	Help	117
11.11	About	117
11.12	Reset cache	118
11.13	Log out	118
<b>12</b>	<b>System monitoring procedure</b>	<b>119</b>
12.1	Checking probe status	119
12.2	Encoder status	119
12.2.1	Encoder fault corrective actions	120
12.2.2	Monitor live media streams	120
12.2.3	Checking memory and CPU utilization	121
12.3	Checking video storage utilization	121
<b>13</b>	<b>Troubleshooting and maintenance</b>	<b>123</b>
13.1	No video playing	123
13.2	User login	123
13.2.1	Client machine not working	123

---

<b>13.3</b>	<b>Install player CAB file</b> .....	<b>124</b>
<b>13.4</b>	<b>License problem sources</b> .....	<b>124</b>
<b>13.5</b>	<b>Capture card debugging</b> .....	<b>124</b>
13.5.1	Blackmagic .....	124
13.5.2	DekTec .....	126
13.5.3	Osprey .....	126
13.5.4	Hauppauge .....	129
<b>13.6</b>	<b>Technical support portal</b> .....	<b>129</b>
<b>14</b>	<b>SNMP notification</b> .....	<b>130</b>
<b>14.1</b>	<b>MIB variables</b> .....	<b>130</b>
14.1.1	MIB variables alert example .....	132
<b>14.2</b>	<b>SNMP notification signaling</b> .....	<b>134</b>
<b>14.3</b>	<b>System alerts</b> .....	<b>135</b>
<b>15</b>	<b>Revision history</b> .....	<b>137</b>
<b>15.1</b>	<b>Volicon Media Intelligence service releases</b> .....	<b>137</b>
<b>15.2</b>	<b>Revision change history</b> .....	<b>137</b>

---

# 1 Introduction

Welcome to the Volicon Media Intelligence service 8.1 Admin Guide.

## 1.1 Purpose and scope

This document will provide the details and instructions necessary to guide you through the Volicon Media Intelligence service configuration and operation, addressing specific system and network administrator functions, including:

- Connecting video sources
- Encoders used to ingest various video sources
- IP network configuration
- Alerting thresholds
- User accounts
- Other system-related parameters in the Volicon Media Intelligence service

This document is also useful for advanced users to gain further understanding of system operations.

## 1.2 About the Volicon Media Intelligence service

The Volicon Media Intelligence service suite of applications transforms content creation, sharing and the monitoring of broadcast products. It allows you to create and distribute high-quality content faster while immediately enabling response to the competition, advertisers and regulatory entities. Most importantly, the Volicon Media Intelligence service enables you to provide an improved product that will increase approval from all audiences.

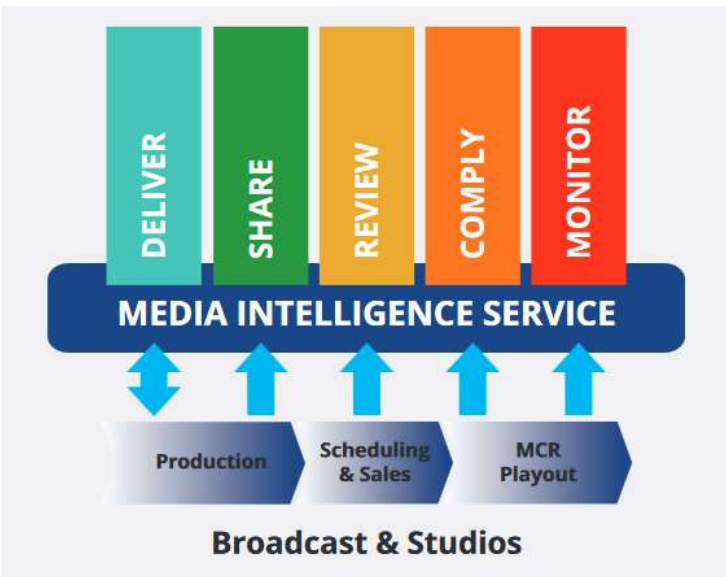

Figure: Volicon Media Intelligence service functional diagram

The Volicon Media Intelligence service continuously ingests videos and audio from multiple sources. Volicon Media Intelligence service works with networks of all sizes. The system is preconfigured with default settings so that small installations can work right out of the box. For larger installations, you can define as many probe servers and their streams in the central server as you need to completely monitor your network.

### 1.3 Conventions used in this manual

Type	Classification
<b>Boldface</b>	Denotes names and labels in the Graphical User Interface (GUI)
<b>Capitalization</b>	Denotes keywords, module names, components and signal labels
<b>&lt;Boldface&gt;</b>	Denotes push buttons and other similar user input devices
<b>@Hyperlink</b>	Automatic links to other sections in the document denoted by boldface and the “@” prefix



## 1.4 Definitions and acronyms

<b>8VSB</b>	8-level Vestigial Sideband Modulation: Used for ATSC over the air broadcast
<b>AC-3</b>	Dolby Digital Audio Codec 3: Compression used by ATSC
<b>AFD</b>	Active Format Description: Metadata describing format (i.e., 4:3 or 16:9)
<b>ARL</b>	As-run logs: Used to extract a program schedule
<b>ASI</b>	Asynchronous Serial Interface: Used to carry MPEG-TS
<b>ATSC</b>	Advanced Television System Committee: A set of standards for US digital television
<b>Bookmark</b>	Short program segments marked on the Volicon Media Intelligence service server to facilitate auditing and sharing
<b>CALM Act</b>	Commercial Advertisement Loudness Mitigation: The FCC requirement for audio loudness
<b>CEM</b>	Content Export Module: An optional software package to export program clips to social media sites
<b>Clear QAM</b>	Clear Quadrature Amplitude Modulation: A non-encrypted cable video distribution
<b>CC/TT</b>	Closed captioning/SMPTE timed text: Protocols used to add text description to audio
<b>Component video</b>	Analog video with separate red, green, blue (RGB) channels using three RCA connections
<b>Composite video</b>	Analog video over a single RCA connection
<b>Dialnorm</b>	AC-3 metadata used to control playback gain
<b>DPI</b>	Digital Program Insertion: Metadata that allows downstream insertion of commercial or short programs
<b>DPI – in point</b>	Entry point to switch to a different stream
<b>DPI – out point</b>	Return to normal stream

<b>DvB</b>	Digital video Broadcasting: An international suite of digital television standards
<b>Encoder</b>	Volicon Media Intelligence service function that receives and processes media signals
<b>Fault clips</b>	Portions of audio or video stream that fail to meet Volicon Media Intelligence service-quality thresholds
<b>SD/HD-SDI</b>	Uncompressed Standard- or High-Definition (video serial data) Interface
<b>GPI</b>	General-Purpose Interface: Metadata used for broadcast automation
<b>HDMI</b>	High-Definition Multimedia Interface: A digital interface used to transport audio and video short distances
<b>IP</b>	Internet Protocol: Used to send digital data from one computer to another
<b>Metadata</b>	Data-about-the-data: Additional information carried by the program used to describe program details
<b>MH</b>	Media Hub: An internal Volicon Media Intelligence service component
<b>MPEG</b>	Motion Picture Expert Group: An international organization that sets audio and video compression and transmission standards
<b>MPEG-TS</b>	MPEG Transport Stream: A standard container for audio, video and Program and System Information Protocol (PSIP)
<b>Multiview</b>	Volicon Media Intelligence service feature that allows you to configure multiple channels and monitoring widgets into a single display screen
<b>NAVE</b>	Nielsen Audio Video Encoder: Psychoacoustic symbols inserted in programs to facilitate automatic viewer tracking
<b>NTP</b>	Network Time Protocol: An internet standard used to synchronize computer real-time clocks
<b>OTT</b>	Over-the-top program delivery using internet protocols
<b>PID</b>	Packet Identifier: A unique 13-bit value used to identify elementary streams of a program in a single- or multi-program Transport Stream

---

<b>Probe</b>	Ingest server housing one or more encoders
<b>PSIP</b>	Program and System Information Protocol: A method used to transport program metadata (e.g., sub channels, program guide and content ratings)
<b>S-video</b>	Separate video: A variation of composite video that separates luminance (black and white) from chrominance (color) to enhance video quality
<b>Services</b>	A/V program content with the associated metadata
<b>SMPTE</b>	Society of Motion Picture and Television Engineers: Creates numerous technical standards
<b>STB</b>	Set-top box: A device used to make programming available to customers
<b>Storyboard</b>	Sequence of video frames to assist visualization
<b>VANC</b>	Vertical Ancillary data space in digital streams
<b>W3C</b>	World Wide Web Consortium: Sets standards to advance the use of the World Wide Web
<b>XDS</b>	Extended Data Services: Analog NTSC metadata

---

# 2 Volicon Media Intelligence services

Volicon Media Intelligence service has numerous platforms optimized to meet the needs of a wide variety of customers. Systems are customized per customer requirements. Below is an overview of the different system classes.

## **Enterprise**

The Enterprise platform offers the highest degree of scalability with enterprise reliability and the maximum amount of storage. Enterprise systems use RAID 6 for increased reliability.

## **Professional**

The Professional platform provides a cost-effective system for content monitoring, logging and compliance workflows. It serves as a cross-browser and cross-platform solution that offers greater portability, scalability and redundancy, with ease of use and extensibility. A Professional-class system is equipped with RAID 5 and typically a 2U chassis form factor.

## **Scout**

Scout is a cost-effective, yet powerful, video network monitoring device. It enables broadcasters and networks, as well as cable and IPTV operators, to proactively perform quality checks at A/V service handoffs to ensure the highest quality experience for customers. Scout is the smallest server, using a 1U chassis that supports a single capture card.

# 3 Servers

Volicon Media Intelligence service offers a number of different rack-mounted servers to meet customer requirements.



Figure: Typical Volicon Media Intelligence service server

## 3.1 Server dimensions and power requirements

Server	Hard drive storage capacity	Power requirements – All supplies 50/60 Hz	Height is multiple 1U (1.74 inch, 44.45 mm)	Weight
Scout	1 bay	Single 200W 100-240V 4.2A	1U x 14.0" (346mm) deep	12.8 lbs (6.8kg)
Enterprise TS	4 RAID hot swap 1 aux bay	Redundant supplies 700W 100-140V 8.5-6.0A 750W 180-240V 5.0-3.8A per supply	1U x 25.6" (650 mm) deep	36 lbs (16.3kg)
Enterprise TS	8 RAID hot swap 1 aux bay	Redundant 700W supplies 100-240V 10.0-4.0A per supply	2U x 25.5" (648mm)	52 lbs (26.6kg)
Enterprise	8 RAID hot swap 1 aux bay	Redundant 800W supplies 100-240V 10.0-4.0A per supply	3U x 25.5" (648mm) deep	72 lbs (32.7kg)
Enterprise	16 RAID hot swap 2 aux bays	Redundant 800W supplies 100-240V 10.0-4.0A per supply	3U x 25.5" (648mm) deep	72 lbs (32.7kg)
Enterprise TS	24 RAID hot swap 2 aux bays	Redundant 900W supplies 100- 240V 11.0-4.5A per supply	4U x 26.0" (660mm) deep	75 lbs (34.0kg)

Table: Server space and power requirement

---

## 3.2 Mounting, power, basic connections

Servers mount in standard 19-inch racks. Follow your rack manufacturer's mounting instructions for safe and stable mounting. If the server's power supply has a 110/240 switch, make sure to set it to the proper voltage (120/240 VAC, 50/60 Hz).

Plan for your rack space and cooling requirements by creating a table similar to the one shown above. List your servers, set-top boxes and related equipment. If possible, include a PC or laptop dedicated for use with the Volicon Media Intelligence service servers.

### Access and peripherals

- It is recommended to attach a dedicated display, keyboard and mouse so that there is no delay in logging in to the server during urgent service.
- Attach LAN and video cables as needed per application.

### 3.2.1 Power distribution

Servers should preferably be on dedicated circuits so that if one trips, it will not affect more than one power supply module per server.

Volicon Media Intelligence service systems should be connected to a UPS or a similar high-availability power supply.

### 3.2.2 Total power

Add the power requirements of all other on-site equipment to obtain total system power consumption.

### 3.2.3 HVAC

Ensure your HVAC has sufficient cooling capacity to handle the total power (watts) of heat dissipated by the servers and your other on-site equipment.

### 3.2.4 STB shelves

If you use set-top boxes (STBs), Volicon Media Intelligence service recommends mounting these in 19-inch racks (482.6 mm) for solid installation. Locate the shelves close to the respective probe server to reduce cable lengths. As an example, see the STB shelf shown below. It fits in a 19-inch 2U-high rack.

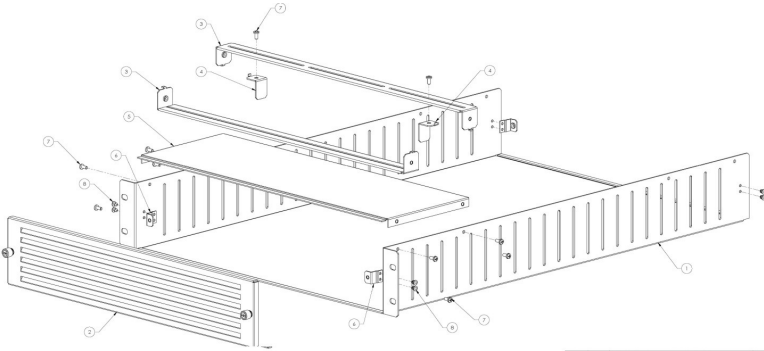

Figure: Set-top box mounting shelf

### 3.2.5 Typical rack layout with set-top boxes

This section describes rack layout and interconnections scenarios. Typical deployment will have a central server, one or more probe servers with capture cards and, optionally, set-top boxes. A small installation may be able to combine the central server and probe functionality in a single physical server.

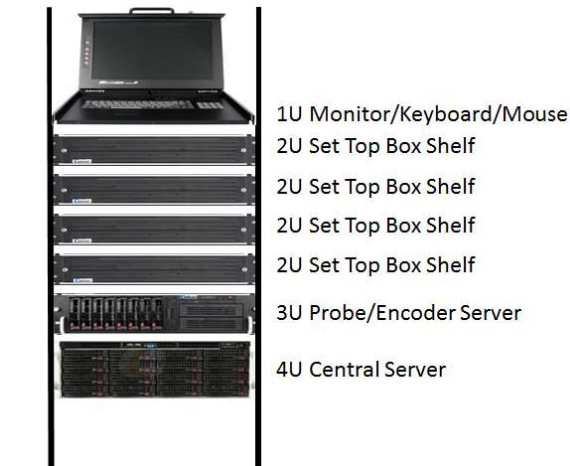

Figure: Typical Volicon Media Intelligence service equipment rack

### 3.3 Server front panel indicators and controls

For security purposes, a locking front cover prevents access to drive bays, auxiliary drives and the power and reset buttons. With the security panel installed, only the system-level status LEDs are visible.

Note: There may be minor differences in panel indicators depending on the specific server and configuration.

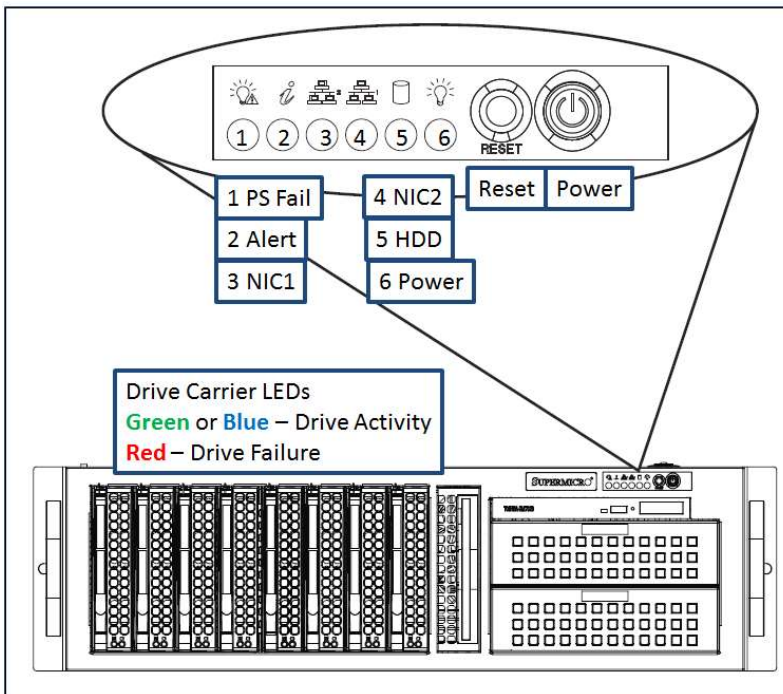

Figure: Typical server indicators and controls (security panel removed)

#### 3.3.1 Power on and shut down

To power up the server, remove the locking front panel security cover and press the power switch.

After powering up the Volicon Media Intelligence service server, wait for the login screen to appear. If you are logging in to the system for the first time, consult the "Read me first" guide, or contact the Volicon Media Intelligence service support team.

Note: Volicon Media Intelligence service runs as a service (configured by default) and *does not* require a user/admin login to operate.



---

To shut down Volicon Media Intelligence service from the console, use the MS Windows <Start> → <Shutdown> sequence. To restart the server, use the <Start> → <Restart> menu.

---

**CAUTION**

DO NOT remove power or press the <Reset> button to reboot the server. This uncontrolled shutdown can corrupt the application database and require re-indexing by a Volicon Media Intelligence service support engineer.

If the Windows UI is not accessible, use the front panel <Power> button to perform an orderly server shutdown

---

### 3.3.2 Server front panel indicators

There are several LED indicators on the control panel, and others on the drive carriers, to keep you informed of the overall system status and the activity and health of specific components. This section explains the meanings of the LED indicators and the appropriate responses.

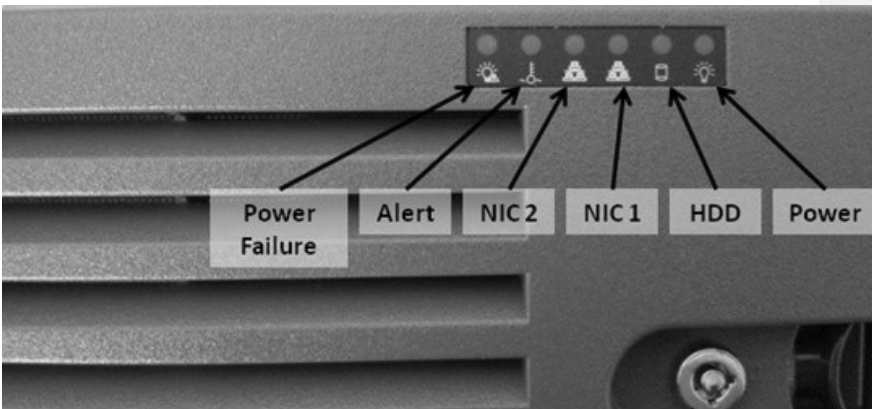

Figure: Volicon Media Intelligence service front panel indicators (security panel in place)

## Indicators:



**Power failure:** When this LED flashes, it indicates one of the power supplies has failed.



Alert status	Description
Constant red	An overheat condition has occurred, possibly caused by cable congestion.
Blinking red (1Hz)	This indicates a fan failure. Check for an inoperative fan.
Blinking red (0.25Hz)	This indicates a power failure. Check for a non-operational power supply.
Constant blue	Local UID has been activated. Use this function to locate the server in a rack mount environment.
Blinking blue	The remote UID is on. Use this function to identify the server from a remote location.

Table: Chassis indicators



**NIC2** indicates network activity on LAN2 when flashing.  
**NIC1** indicates network activity on LAN1 when flashing.



**HDD** indicates IDE channel activity, SAS/SATA drive and/or DVD-ROM drive activity when flashing.



**Power** indicates power is being supplied to the system's power supply units. This LED should normally be illuminated when the system is operating.

### 3.3.3 Drive carrier indicators

Each drive carrier has two status LEDs. They are normally hidden behind the security panel. Remove the panel to access the drive bays.

**Activity LED:** **Green** or **blue** indicates the drive activity and flashes when the drive is accessed.

**Status LED:** **Red** indicates drive failure.

### 3.3.4 Power supply indicator

Some power supplies have a status LED located on the power supply – visible from the rear of the chassis.

- Solid **green** indicates the supply is on and operating normally.
- Solid **amber** indicates the supply is plugged in and turned off or in an abnormal state.
- Blinking **amber** indicates overtemp and the supply temperature has reached 63C. The system will automatically power down if the supply reaches 70C, and restart when the supply cools down to 60C.

## 3.4 Server rear panel connections

Power and video inputs are located on the back panel.

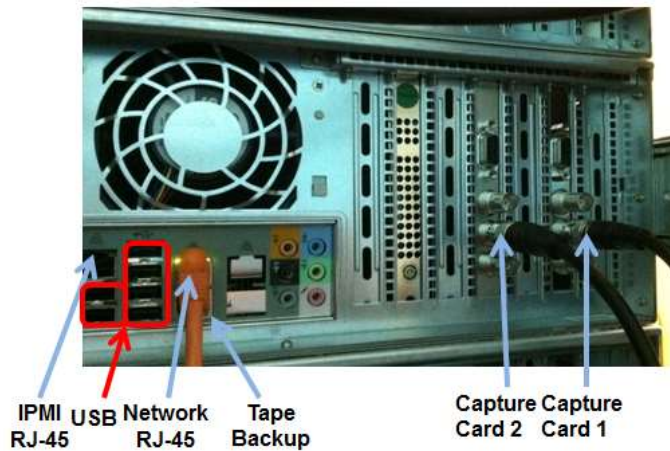

Figure: Typical server rear panel

## 3.5 Capture cards

Volicon Media Intelligence service supports a wide range of RF, analog, baseband and digital video capture cards to meet customer requirements. Capture cards are described in more detail in [Section 8](#).

- Blackmagic: DeckLink Duo, DeckLink Quad, DeckLink SDI 4K, Extreme 4K, Intensity PRO 4K, Mini Recorder, Mini Monitor, Studio 4K
- DekTec: DTA-2111, DTA-2135, DTA-2136, DTA-2137, DTA-2145, DTA-2160
- Hauppauge: WinTV-HVR-2255, 1609
- Osprey: 160e, 460e

---

# 4 Software installation

Volicon Media Intelligence service central server and probe server software are preinstalled and configured by Volicon Media Intelligence service

## 4.1 Central and probe server operating systems

The Volicon Media Intelligence service central server can be installed on 64-bit computers running any of the following Microsoft operating systems:

- Windows 7
- Windows 10
- Windows Server 2012 R2
- AWS Windows 2012 R2

### 4.1.1 Additional Microsoft software

The central server utilizes the following additional MS software packages:

- Microsoft .NET Framework 3.5 SP1
- Microsoft Message Queuing (MSMQ)
- Windows Installer 4.5 Redistributable
- Microsoft Visual C++ 2005 SP1 Redistributable
- Microsoft Updates – turned off during normal Volicon Media Intelligence service operation

### 4.1.2 Third-party software

Volicon Media Intelligence service makes use of several third-party software packages. The following software packages are preinstalled when the system is ordered:

- **Apache:** Web server
- **Hmailserver:** Outgoing mail server
- **Redis:** Object cache
- **MariaDB:** Database
- **PHP:** Scripting

---

## 4.2 Client workstation

PC client may be either 32- or 64-bit computers running the following operating systems:

- Microsoft Windows 7
- Microsoft Windows 10
- Apple Mac

### 4.2.1 Client-side browsers

Volicon Media Intelligence service supports the following browsers:

- Chrome uses **HTML5** (Mac and Windows).
- Edge uses **HTML5**.
- Firefox uses **Silverlight V5**.
- Internet Explorer 11 uses **ActiveX**.
- Safari uses **HTML5** (Mac O/S only).

---

#### Note

You need to run SetIE64.exe if you're using the 32-bit version of IE. Download it from the Volicon Media Intelligence service site.

---

## 4.3 Initial Volicon Media Intelligence service deployment

Volicon Media Intelligence service installs and tests the customer configuration prior to shipping. On-site installation consists of integrating the servers into your corporate IPv4 network and connecting the encoders to ingest the appropriate channels. Once the system is up and running, the Volicon Media Intelligence service administrator needs to configure social media publishing profiles and create user accounts.

## 4.4 Optional Volicon Media Intelligence service modules

Volicon Media Intelligence service is highly configurable to meet customer needs. Below is a partial list of optional Volicon Media Intelligence service modules.

- **Loudness monitoring:** Compliance verification

- 
- **Content matching:** Identifies when specific content is aired
  - **Advanced Content Export (ACE):** Automatically creates assets and uploads them to predefined locations
  - **Trigger clipping:** Integrates Volicon Media Intelligence service to third-party monitoring systems
  - **NAVE decoding, logging and alerting:** Insures proper transmission and delivery of NAVE codes to Nielsen monitoring equipment
  - **Scheduled recording:** Automatically controls the set-top box to monitor relevant media sources
  - **Ratings import:** Imports viewer ratings
  - **Quality of Experience (QoE or QoX):** Monitors logged content for a variety of signal faults
  - **As-run log (ARL) integration:** Integrates Volicon Media Intelligence service with existing automation systems
  - **Active directory (AD) integration:** Integrates Volicon Media Intelligence service into the AD domain to allow single login
  - **Embedded AC-3 capture:** Natively processes AC-3 audio-eliminating need for external AC-3 decoder
  - **DvB subtitles capture:** Monitors and alerts missing DVB subtitles
  - **Multiviewer:** Watches multiple programs on the network wall
  - **Multicast:** Live streams either high-quality original programs or low-resolution proxy across the enterprise
  - **DPI monitoring:** Frames accurate monitoring to insure DPI messages were conveyed properly
  - **Digital audio S/PDIF interface:** An ingest of digital audio streams
  - **Over-the-top (OTT) monitoring:** Multiplatform streaming media logging and monitoring
  - **Archiver:** Manages storage and retrieval of content
  - **Closed caption (CC) monitoring:** Monitors and alerts closed captioning service

## 4.5 Managing Volicon Media Intelligence service software updates

Volicon Media Intelligence service support is responsible for installing central server (CS) and probe server software updates.

Updates to the Internet Explorer Active-X viewer, a component of the CS, are automatically pushed to the client when the user logs in. Installing the ActiveX viewer requires admin privileges.

---

## 4.6 Upgrading from previous versions of Volicon Media Intelligence service

There are significant differences between previous versions of Volicon Media Intelligence service. Please contact Volicon Media Intelligence service for additional information about upgrading.

# 5 Adding Volicon Media Intelligence service servers to your network

Assign each server a static IPv4 address. If you are using the internet for your connections, place firewalls between your Volicon Media Intelligence service probe servers and their internet connection, and between the central server and its internet connection. As a minimum, assign a DNS entry to the central server to facilitate client access.

## 5.1 IP port utilization

Numerous TCP/UDP ports are used for intra-application communication and to provide Volicon Media Intelligence service client access.

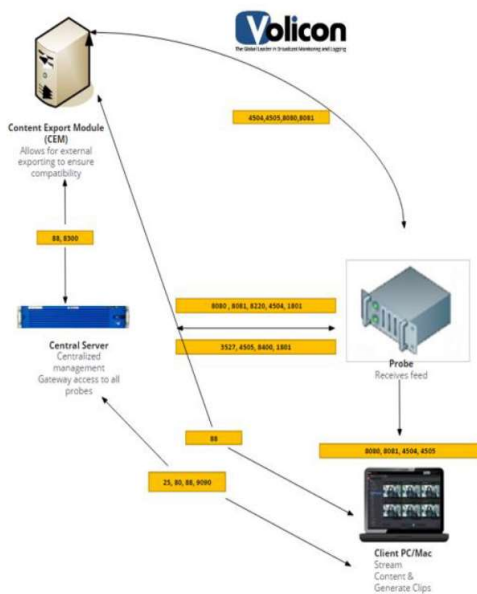

Figure: System intercommunication



Probe			
Service	Incoming	Outgoing	Protocol
Listener service	8220		HTTP (TCP)
Media hub	8080		HTTP (TCP)
Volicon Live Streamer port	4505		TCP
Volicon Streamer port	4504		TCP
MediaHub	8080	8080	TCP
MediaHub	8081	8081	TCP
MSMQ		1801	UDP
CEM	88	88	TCP

Central server			
Service	Incoming	Outgoing	Protocol
Access to probe's listener service		8220	HTTP (TCP)
Web server port (if using SSL)		8080	HTTP (TCP)
MSMQ	1801, 3527		UDP
SNTP		25	TCP
Volicon Live Streamer port		4505	TCP
Volicon Streamer port		4504	TCP
MediaHub	8080	8080	TCP
MediaHub	8081	8081	TCP
WebSocket	9090	9090	TCP
CEM port	8300	8300	TCP
HTTP	80	80	TCP
CEM port	88	88	TCP

Client			
Service	Incoming	Outgoing	Protocol
Access to Streamer		4504	TCP
Access to Live Streamer		4505	TCP
MediaHub	8080	8080	TCP
MediaHub	8081	8081	TCP
SNTP	25		TCP
Web Socket	9090	9090	TCP
HTTP	80	80	TCP
CEM	88	88	TCP

Content export module			
Service	Incoming	Outgoing	Protocol
Volicon Live Streamer port		4505	TCP
Volivon Streamer port		4504	TCP
MediaHub	8080	8080	TCP
MediaHub	8081	8081	TCP
CEM port	8300	8300	TCP
CEM port	88	88	TCP

Table: IP port utilization

## 5.2 Network bandwidth

Provide sufficient bandwidth between the server and the monitoring facility. Size the bandwidth to be 1.2-1.5 times the sum of the viewed stream's bandwidth, with a minimum connection speed of 10 Mbps.

---

# 6 Initial O/S level setup

Volicon Media Intelligence service servers run different versions of the Microsoft Operating System and come with the Volicon Media Intelligence service suite preinstalled. The administrative task is to integrate the servers into your network and set up end user accounts.

## 6.1 Active directory (AD) integration

AD integration is an optional Volicon Media Intelligence service module. A Volicon Media Intelligence service support engineer will need to be involved to configure the Volicon Media Intelligence service server.

### 6.1.1 Prerequisites

The following prerequisites need to be met for the AD integration to proceed:

- The support engineer needs to know the IP address or the fully qualified domain name (FQDN) of the AD server. The FQDN is more flexible and is preferred.
- Add the Volicon Media Intelligence service web server to the AD domain.
- Create a simple domain user with a non-expiring password and notify support.
- Provide the support engineer with your organizational units (OUs) and their basic structure.
- Upgrade all the Volicon Media Intelligence service servers to the latest qualified build prior to integration.
- Configure all your client browsers to have the web server address in their intranet zone or IE trusted zone.

### 6.1.2 AD operation

- After all prerequisites are met, you must define several groups in the Volicon Media Intelligence service. To do so, you can access the system with a non-AD password through the URL **http://<server>/admin**. When using AD integration, the user's set of permissions (including accessible channels and maximum number of concurrent channels played) is defined on the Volicon Media Intelligence service groups (user management section).
- You must also create identical group names as defined in Volicon Media Intelligence service in the AD. Once completed, the administration of users'

---

access to Volicon Media Intelligence service and their privileges will only be administered through the AD by adding or removing users as members of the different groups. Note: One exception is the number of concurrent channels. By default, there is no limit; if defined, the Volicon Media Intelligence service settings will be used. Furthermore, if multiple groups define the number of concurrent channels, the highest number will be used (even if it is set to unlimited).

- Initially, the user accesses the Volicon Media Intelligence service system through a browser with only an IP address or a domain name. Access to the Volicon Media Intelligence service system is provided automatically according to the user's assigned group(s) in AD, matching the user by group name to the defined Volicon Media Intelligence service groups. If the user is a member of several groups, their effective permissions will be the sum of all permissions of those groups.
- The user's name is automatically created internally within the Volicon Media Intelligence service upon first login. It is then associated with the user-generated content in the Volicon Media Intelligence service (e.g., clips, programs, etc.).

## 6.2 Antivirus exclusion storage areas

Ensure that any installed antivirus program does not interfere with the Volicon Media Intelligence service programs/services. Antivirus programs can use system resources needed by Volicon Media Intelligence service services, causing them to hang or crash.

- Turn off all "on-access" scanning.
- Schedule virus definition updates and system scans to occur during low-usage times and when technicians are available to verify that restarts (if any) have completed running and have not hung up the system.
- Certain directories need to be open and free for continuous system access.
- Ensure that the following folders are removed from scans:

C:\ProgramData\Redis	Object cache
C:\ProgramFiles\Redis	Object cache
C:\ProgramFiles\MariaDB 10.2	Database
C:\ProgramFiles\Volicon \	Volicon Media Intelligence service software
C:\thumbnails	Media thumbnail storage
C:\video\	Content storage

---

Table: Antivirus exclusion configuration

## 6.3 Remote server access

Volicon Media Intelligence service administration management access uses the same web-based user interface as other users. As an administrator (with admin privileges) you have access to system level configuration features that provide the ability to add and delete user accounts.

From time to time, direct access to the Windows server may be required. If the particular server is not equipped with local user access capabilities, the built-in Microsoft RDP Remote Desktop feature is handy. There are several precautions to keep in mind when using MS Remote Desktop to prevent interfering with Volicon Media Intelligence service audio and video processing.

### 6.3.1 Server-side Microsoft RDP

Each server that requires remote access will first need to have the feature enabled. Afterward, select which accounts are able to remotely access the computer. The Windows administrator account is automatically granted access when Remote Desktop is set up.

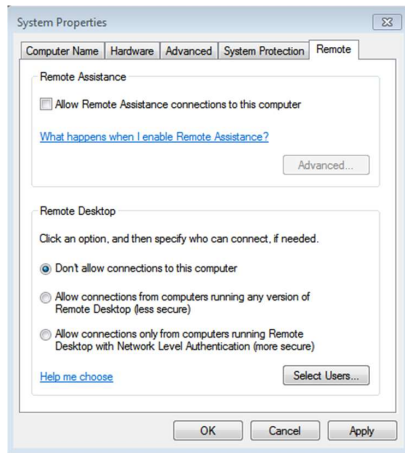

Figure: Server-side Remote Desktop

## 6.3.2 RDP client

Configure your settings by the following steps when you are using a Remote Desktop connection (MSTSC- Microsoft Terminal Services Client).

1. From the Start menu, find **<Remote Desktop connection>**.
2. Open **<Remote Desktop connection>**.
3. Click on the **<Local resources>** tab.
  - Note: If you are setting up remote access from Windows XP (no longer supported by Microsoft), change the “Remote computer sound” setting to “Leave at remote computer”, as this is required to ensure that the system remains working correctly.
  - If you are setting up remote access from Windows 7 or later, use the defaults for “Remote audio”.
4. Uncheck “Printers” under **<Local devices and resources>**. Otherwise, the system will generate errors while trying to find and install printer drivers that do not exist on the server.
5. Optionally, select the clipboard to enable file copy operations between the server and the client PC. To save your changes, go to the **<General>** tab and press **<Save>**.



Figure: Windows 7 RDP local resources

### 6.3.3 Login

1. Open **<Remote Desktop connection>**.
2. Enter the URL or IP address of the server.
3. Enter your username.
4. If you check "Allow me to save credentials", Windows will save your login information. Do this only on a secure PC you control.
5. Press: **<Connect>**.

Note: Only one person can be logged in at a time. A successful login will terminate an existing session.

If your computer is unable to connect to the remote server, it throws this error message.

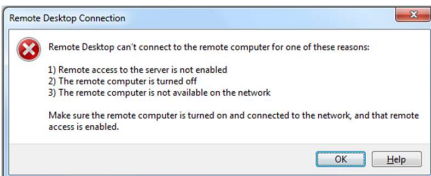

Figure: RDP unable to connect to remote server

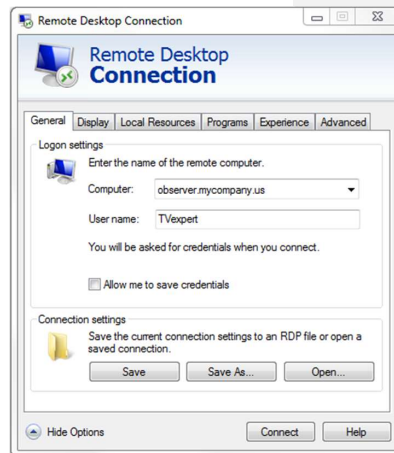

Figure: Remote Desktop login

### 6.3.4 Terminate remote session

Closing the window in Windows 7 and later will automatically terminate the session. If you are still using Windows XP (no longer supported by Microsoft), you need to explicitly terminate the session, not just close the window. Just closing the window will leave you logged in.

---

# 7 RAID disk drive array

RAID, an acronym for "Redundant Array of Independent Disks", is a storage technology that combines multiple hard drives to store data on them as if they were one logical unit. RAID takes multiple physical disks and makes them appear and function as a single hard disk drive.

Most RAID configurations support write caching. Write caching improves write performance by caching write data in memory and then copying data to the disk array. These systems include battery backup of controller memory to prevent data loss or corruption in the event of a power failure.

Except for the smallest system types (Scout), all Volicon Media Intelligence service servers use some form of RAID to insure data integrity. Depending on configuration, three RAID variants – 1, 5 and 6 – are used.

Volicon Media Intelligence service uses enterprise-class SATA drives for maximum performance and reliability.

## 7.1 RAID variants

### RAID 1

RAID 1, or disk mirroring, is the process of replicating the data to more than one disk. Both the disks are operational at the same time so the system can read data from both simultaneously. This enhances the speed of read operations. However, the write operations are slower, as the system executes each write operation twice – once on each disk. A minimum of two disks are required for a RAID 1 array.

### RAID 5

RAID 5 can tolerate failure of *any* drive in the array without losing a single byte of stored data. RAID 5 is block-level striping with distributed parity. Striping and data are distributed by independent read and write operations. In a "write" operation, data to be recorded is striped across all array members interspersed with a parity block and distributed in order to place one segment containing the parity checksum on a different drive within each striping cycle. Sometimes defined as rotating parity, this scheme is the reason why it doesn't matter which drive in the array fails. A minimum of three disks are required for a RAID 5 array.



---

## RAID 6

RAID 6 can tolerate the concurrent failure of two hard drives while precluding data loss and system downtime. RAID 6 provides a second layer of redundancy by means of two separate, independent parity blocks within each stripe written to the data storage subsystem array and distributed among each of the active members in the array. Thus, another moniker for RAID 6 is "double-parity RAID".

RAID 6 requires a minimum of four drives, but it will typically have a significantly larger number of array members since performance, fault tolerance and cost efficiency are improved with a larger population.

## 7.2 RAID controllers

Volicon Media Intelligence service uses [Broadcom](#) 9271-4i or 9271-8i RAID controllers. The 4i has 4 6 Gb/s SATA or SAS ports; the 8i has 8 6 Gb/s SATA or SAS drives. Except for the number of ports, the controllers are identical. The 4i is used with the 4, 16, 24 HDD chassis. The 8i is used with the 8 HDD chassis.

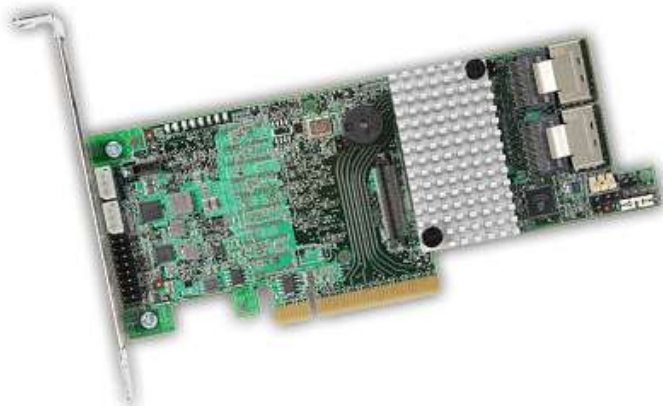

Figure: 9271-8i controller

## 7.3 Accessing the RAID controller

As part of the initial build, Volicon Media Intelligence service installs the appropriate RAID controller. To access the controller, click the **<MegaRAID>** icon located on the server desktop.

The controllers will be automatically discovered in most cases. The controller on the local server will be found; however, in some cases, it may include another networked server's RAID controller.

Note the "Health" column in the figure below. It indicates whether or not the array is working correctly without the need to log in.

The controllers will be automatically discovered in most cases. The controller on the local server will be found; however, in some cases, it may include another networked server's RAID controller.

Note the "Health" column in the figure below. It indicates whether or not the array is working correctly without the need to log in.



Figure: RAID controller Desktop icon

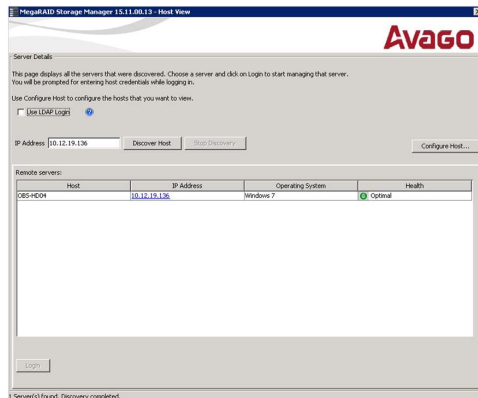

Figure: RAID controller automatic discovery

Double click to access the desired controller and log in to the controller. The controller uses the same credentials as the Windows login.



Figure: RAID controller login

## 7.4 Main megaRAID screen

The main screen presents overall health status and details about individual drives. At the bottom of the screen, not shown, is a scrolling log file displaying real-time RAID information.

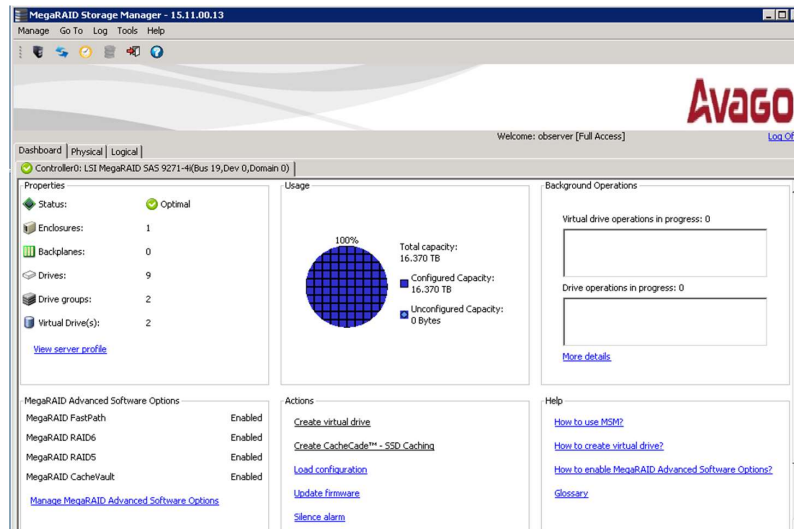

Figure: RAID system main screen

Click the **<Physical>** tab to display information about each drive in the system.

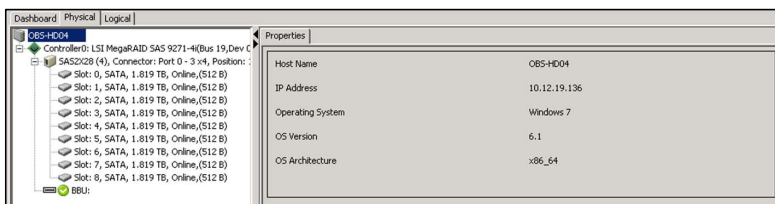

Figure: Individual drive status

### 7.4.1 Silencing RAID alarm

In addition to an email notification, the controller sounds an audible alert. To silence the alarm, press the **<Silence alarm>** link in the center pane towards the bottom of the dashboard.

## 7.5 Email alerts

The RAID controller can be set to send out email alerts. Click on **<Tools>** → **<Monitor configure alerts>**. Volicon Media Intelligence service recommends limiting emails to the most critical and fatal to minimize the number of emails sent by the system.

Click the **<Mail server>** tab to set up the outgoing mail server and the **<Email>** tab to enter one or more recipient email addresses.

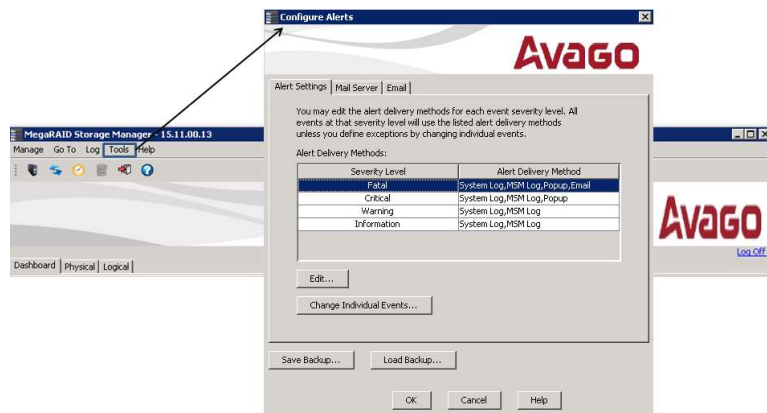

Figure: RAID email alerts

## 7.6 Hard disk drive (HDD) replacement

To replace an HDD on the hot swappable disk array, first remove the faulty bad drive, then insert a new replacement HDD. The RAID controller will automatically start rebuilding the array.

If the controller is reporting multiple drive failures, try reseating the hot swappable drives first.

---

# 8 Capture cards and breakout cables

Volicon Media Intelligence service supports multiple A/V formats and associated capture cards. The capture card converts the analog or digital source for Volicon Media Intelligence service processing, evaluation and storage. Unlike other applications, Volicon Media Intelligence service continuously ingests and records each channel. As such, you need to dedicate a capture card port per channel. If you are using set-top boxes, they also will need to be configured on a per-monitored-channel basis.

Input	Output	Chan	Mfg.	Card Name
RF-8VSB/QAM	n/a	1	Hauppauge	HVR-2255
RF-8VSB/QAM	n/a	4	Hauppauge	01609
RF-8VSB/QAM/DVB	1	1	DekTec	DTA-2111
RF-DVB-C	ASI	2	DekTec	DTA-2136
RF-DVB-S2	ASI	2	DekTec	DTA-2137C
Analog	Yes	1	Blackmagic	Intensity Pro 4K
Analog	Yes	1	Blackmagic	Studio 4k
Analog	n/a	1	Osprey	260e
Analog	n/a	4	Osprey	450e
Analog	n/a	4	Osprey	460e
HDMI	Yes	1	Blackmagic	Intensity Pro 4K
HDMI	Yes	2	Blackmagic	Extreme 4k
HDMI	Yes	1	Blackmagic	Studio 4k
HDMI	n/a	1	Blackmagic	Mini Recorder
n/a	HDMI	1	Blackmagic	Mini Monitor
SD/HD-SDI	Yes	2	Blackmagic	DeckLink Duo

SD/HD-SDI	Yes	4	Blackmagic	DeckLink Quad
3G-SDI	n/a	1	Blackmagic	Mini Recorder
n/a	3G-SDI	1	Blackmagic	Mini Monitor
6G-SDI	Yes	2	Blackmagic	Extreme 4k
6G-SDI	Yes	1	Blackmagic	DeckLink SDI 4K
6G-SDI	Yes	1	Blackmagic	Studio 4k
ASI/SD-SDI	Yes	1	DekTec	DTA-2145
ASI/SD-SDI	Yes	3	DekTec	DTA-2160
Ethernet	n/a	1	DekTec	DTA-2160

**Tech tip**

In instances where the video card supports video output, the output feed may be used to directly drive a video monitor. This capability must be configured using a probe manager.

## 8.1 Blackmagic

Volicon Media Intelligence service supports multiple **Blackmagic** acquisition cards up to a maximum of six.

### 8.1.1 Intensity PRO 4K

The Intensity Pro is a high-definition capture card. The card and breakout cable are shown below. The card supports HDMI and component, S-video and composite analog inputs.

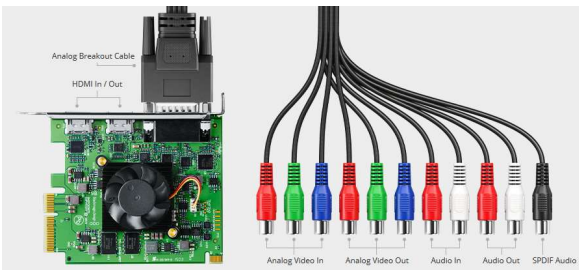

Figure: Intensity Pro & breakout cable

The breakout cable supports component video using the R, G, B connectors; S-video using the G, B connectors; and an external adapter and composite video using the B connector. Analog audio connects to the red (left) and white (right) audio connectors.

Source Type	Intensity Pro (Connector color)	Label
Component RGB (red)	Red	R-Y input
Component RGB (green)	Green	Y input
Component RGB (blue)	Blue	B-Y input
S-video (Mini-DIN)	Green	Y input
Requires adapter	Blue	B-Y input
Composite video (yellow)	Green	Y input
Stereo audio (white)	White	Right input
Stereo audio (red)	Red	Left input

Table: Intensity Pro input connections

### 8.1.2 DeckLink Extreme 4K

Extreme 4K supports two SDI audio and video – one analog audio and video and one HDMI input.

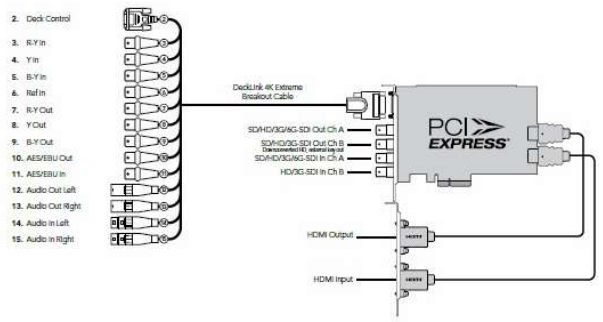



Figure: DeckLink Extreme 4K card

Figure: DeckLink Extreme and breakout cable



### 8.1.3 DeckLink SDI 4K

Blackmagic DeckLink SDI 4K supports a single SDI input.



Figure: DeckLink SDI card

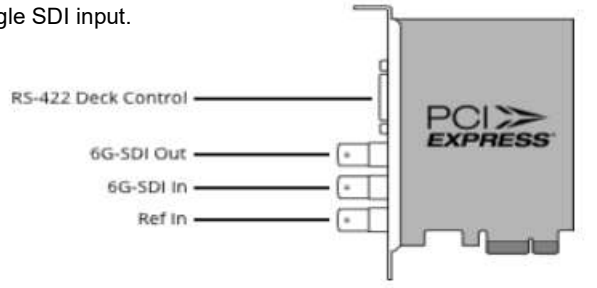

Figure: DeckLink SDI connector connections

Connect the SDI source (from deck) with coax M to the Blackmagic DeckLink SDI card's BNC connector input.

### 8.1.4 DeckLink Studio 4K

DeckLink Studio 4K has single SDI A/V, analog A/V and HDMI inputs.



Figure: DeckLink Studio 4K

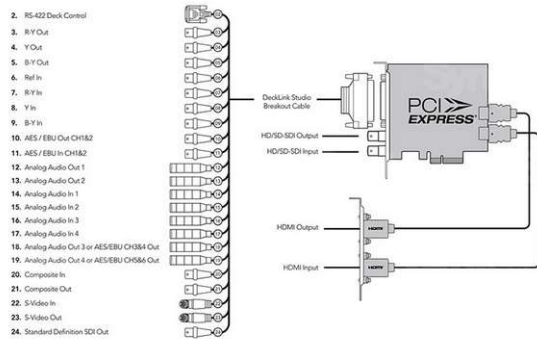

Figure: DeckLink Studio connections

### 8.1.5 DeckLink Duo

The DeckLink Duo adapter supports dual HD/SD inputs/outputs via two SDI interface connections.



Figure: DeckLink Duo

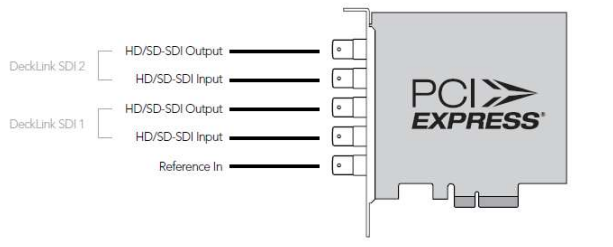

Figure: DeckLink Duo SDI/HD adapter

### 8.1.6 DeckLink Quad SDI

Volicon Media Intelligence service supports the Blackmagic DeckLink Quad SDI card. As the name implies, it supports up to four inputs. The card has Mini BNC SDI connectors. An adapter cable is used to connect to standard BNC connectors.



Figure: Blackmagic DeckLink Quad SDI-SD/HD

### 8.1.6.1 DeckLink Quad SDI-SD/HD connector diagram

Connections are made to the SDI inputs as shown.

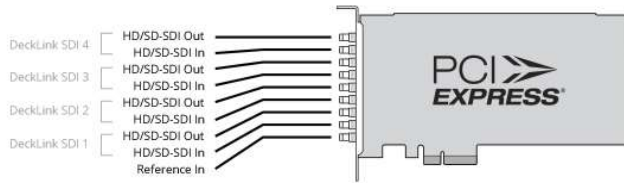

Figure: DeckLink Quad SDI-SD/HD connector diagram

### 8.1.6.2 Breakout cable BNC to Mini BNC adapter

You will need the BNC to Mini BNC connector breakout cable to use the DeckLink Quad SDI-SD/HD card. The cable is pictured below.



Figure: BNC to Mini BNC adapter cable

### 8.1.7 DeckLink Mini Recorder

DeckLink Mini Recorder has a single SDI and HDMI input.

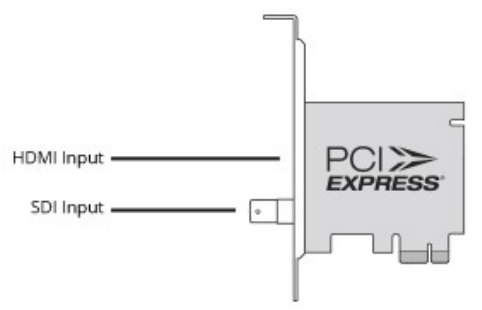



Figure: DeckLink Mini Recorder card

Figure: DeckLink Mini Recorder connection

### 8.1.8 DeckLink Mini Monitor

DeckLink Mini Monitor has a single SDI and HDMI output to drive an external monitor.



Figure: DeckLink Mini Monitor output card

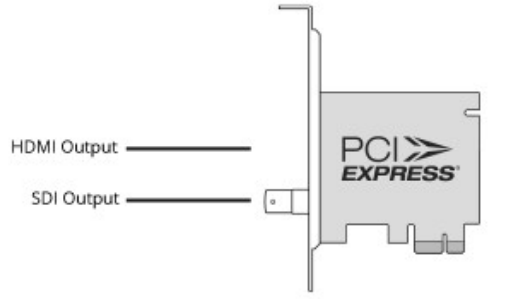

Figure: DeckLink Mini Monitor connection

## 8.2 DekTec

Volicon Media Intelligence service supports multiple **DekTec** cards. Driver is common to all cards – DekTec DTA-xxxx cards ver 4.10.0.144 (dated 10/29/2014).

### 8.2.1 DekTec DTA-2111

Multiprotocol modulator supports 8VSB/DVB-C/DVB-T/QAM-B/QAM-C. The card is used to drive RF monitors.



Figure: DekTec DTA-2111 digital modulator

---

### 8.2.2 DekTec DTA-2136

The DekTec DTA-2136 has a dual-channel DVB-C receiver. The card includes an ASI output port for each channel for local monitoring.



Figure: DekTec DTA-2136

### 8.2.3 DekTec DTA-2137C

The DekTec DTA-2137C is a dual-channel satellite receiver card. Each input has a corresponding output for local monitoring.



Figure: DekTec DTA-2137C1

### 8.2.4 DekTec DTA-2145

The DekTec DTA-2145 has an input and output port configurable as ASI or SDI.

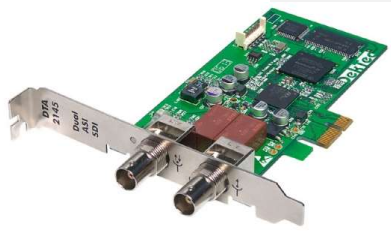

Figure: DekTec DTA-2145

#### 8.2.4.1 DekTec DTA-2160

The DekTec DTA-2160 has connector ports for 1- Gig E and 3-ASI interfaces:

Physical location from top	Port type	Logical port number
1	Gig E	Port 4
2	ASI 1	Port 1
3	ASI 2	Port 2
4	ASI 3	Port 3

Table: DekTec TDA-2160 connector ports

The top connector is the Gig E connector – called port 4 – followed by the ASI port 1, ASI port 2 and ASI port 3 interfaces.

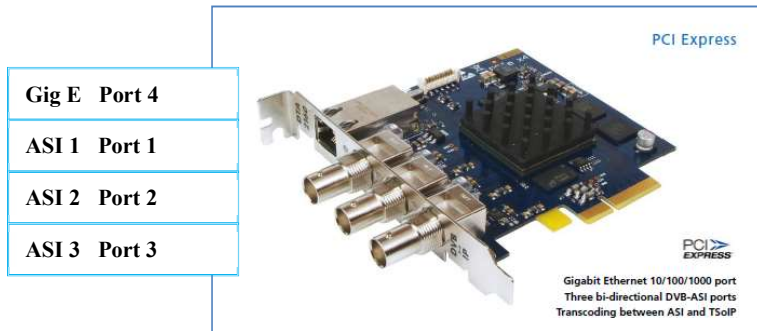

Figure: DekTec card

## 8.3 Hauppauge

Volicon Media Intelligence service supports the Hauppauge 01609 and HVR-2255 capture card.

### 8.3.1 Hauppauge 01609

The **Hauppauge 01609** is a quad 8VSB ATSC/QAM capture card able to ingest ATSC 4 over-the-air or unencrypted/unswitched cable (QAM) channels.



Figure: Hauppauge 01609

### 8.3.2 Hauppauge HVR-2255

The **Hauppauge** WinTV-HVR-2255 is used to ingest a single over-the-air (8VSB) or unencrypted cable (QAM) channel. The FM tuner and analog A/V baseband inputs are not supported in Volicon Media Intelligence service.

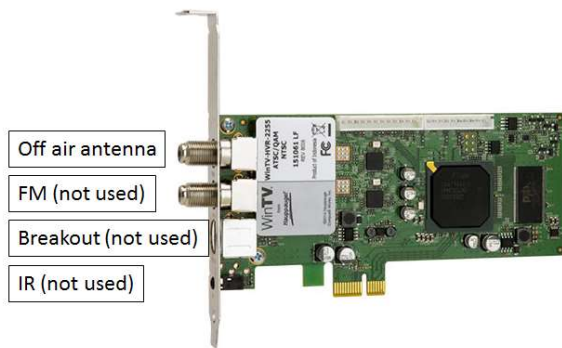

Figure: Hauppauge HVR-2255

## 8.4 Osprey

Volicon Media Intelligence service supports multiple **Osprey** capture cards. Osprey cards are used to ingest up to a maximum of four analog channels per card.

### 8.4.1 Osprey 260e

The 260e supports component, S-video and composite video and balanced or unbalanced stereo inputs.

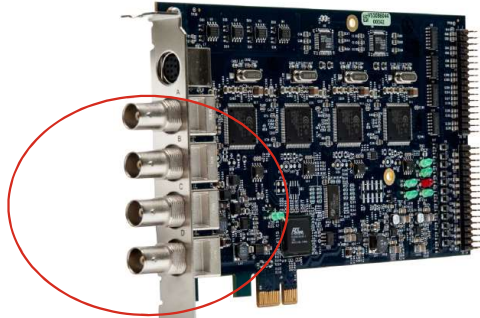

Figure: Osprey 260e capture card



## 8.4.2 Osprey 460e

The Osprey-460e supports four composite video inputs. It supports four BNC composite video inputs. A breakout cable is used to connect four stereo audio channels. The 460e replaces the earlier 450e.



**Input Video Connectors**

Figure: Osprey 460e capture card

The breakout connector provided with the Osprey card has four left/right, unbalanced audio inputs.



Figure: Osprey breakout cable

Volicon Media Intelligence service encoder channels are configured as follows:

- Video Input A and Audio Left 1 / Right 1
- Video Input B and Audio Left 2 / Right 2
- Video Input C and Audio Left 3 / Right 3
- Video Input D and Audio Left 4 / Right 4

### 8.4.2.1 Audio breakout cable 9 Pin Mini Din

The pin assignment for the Osprey 450e and 460e audio breakout is as follows:

1. Audio input	Left 1
2. Audio input	Right 1
3. Audio input	Left 2
4. Audio input	Right 2
5. Audio input	Left 3
6. Audio input	Right 3
7. Audio input	Left 4
8. Audio input	Right 4
9. Ground	Ground

Table: Osprey audio breakout

### 8.4.2.2 Composite video interconnect diagram

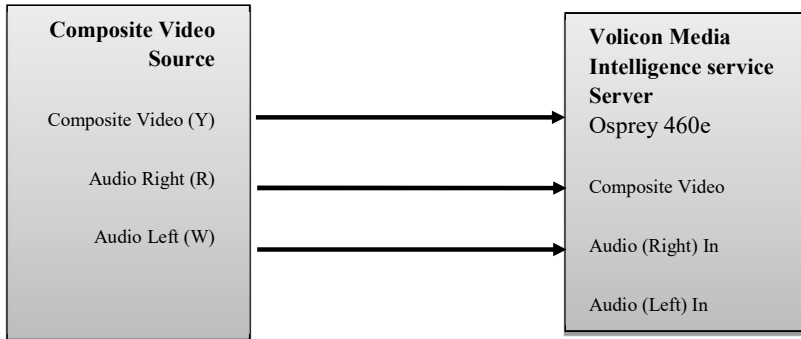

### 8.4.2.3 460e rack mount breakout panels

The 460e capture card supports rack-mounted breakout panels. These can be used to facilitate cabling or support balanced audio using industry standard XLR connectors.



Figure: Composite video and stereo audio

---

It provides rack connection to the four composite video and stereo audio components. This is identical to the flying lead breakout cable.



Figure: Video breakout panel

It provides rack connection to the four video channels configured individually as: component, S-video and composite.



Figure: Balanced audio breakout panel

Provides rack connection to four balanced stereo channels.

## 8.5 Set-top box interconnect

If you are using a set-top box (STB) as an input source, assign one STB per encoder input and connect the output of each STB to the associated capture card input connector. Composite, component and HDMI interfaces are currently supported, depending on the specific capture card.

Normally a STB is statically set to a particular channel for 24 x 7 ingest of that channel. Optionally, the encoder may be configured as virtual STB remote control, allowing Volicon Media Intelligence service to select channels either automatically via a schedule or manually by individual users.

---

### Tech tip

Volicon Media Intelligence service is recording and logging content; as such, it is only able to support HDMI without HDCP.

---



Figure: Typical STB rear panel

---

# 9 What NOT to do on the server side

This section lists events and configurations that should not be applied to any of the Volicon Media Intelligence service servers.

- Do not run a web client application on the Volicon Media Intelligence service encoder or central server.
- Install antivirus software with caution (see section “Antivirus Excluded Storage Areas”).
- Do not load/execute any additional applications on the server.

---

# 10 Volicon Media Intelligence service login

1. Enter the URL provided or IP address of the Volicon Media Intelligence service central server.
2. You will then be prompted for your login credentials (username/password).

---

## Tech tip

Add the IP address or the Volicon Media Intelligence service domain name to the "Trusted sites" list in Internet Explorer.

---

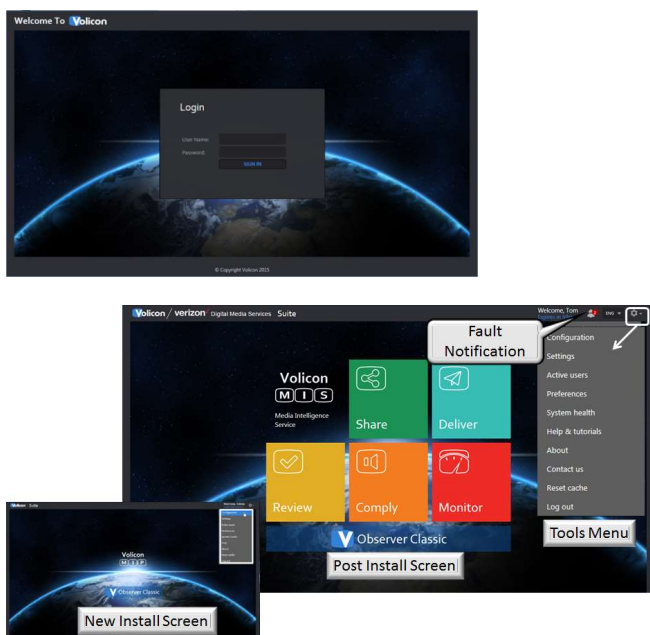

Figure: Volicon Media Intelligence service home page with <Tools> dropdown

---

Assuming you entered your account credentials correctly, you will be greeted with the Volicon Media Intelligence service home page. The specific icons displayed depend on your account settings and the installed Volicon Media Intelligence service options. Depending on the specific configuration of a new build, you may not see any Volicon Media Intelligence service feature icons during the initial login. Regardless of configuration, the **<Tools>** menu in the upper-right corner is always available.

---

#### Tech tip

If you log in to the server running the previous version of Volicon Media Intelligence service, you will be greeted by the Volicon Media Intelligence service welcome screen.

---

## 10.1 Logging out

To log out, click the **<Gear>** icon at the upper-right corner of any Volicon Media Intelligence service page. The **<Gear>** icon appears on all pages, so you don't have to go back to the home page to log out. This opens another menu; click on **<Log out>** at the bottom. Volicon Media Intelligence service asks you to confirm that you really want to log out. As with the home page, the specific options you see are dependent on your account settings.

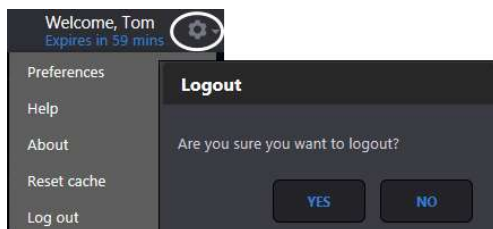

Figure: Volicon Media Intelligence service logout

## 10.2 Internet Explorer settings

For full functionality, the Volicon Media Intelligence service currently supports Internet Explorer versions 10 and higher in both 32-bit and 64-bit. When using Internet Explorer, you must set "Compatibility mode".

1. After you log in to Volicon Media Intelligence service, left click the **<Gear>** symbol at the upper-right of IE; then choose "Compatibility view settings".  
Note: This is the IE tools icon, not the lower tool icon for Volicon Media Intelligence service.

- The URL or IP address of the Volicon Media Intelligence service server should automatically populate under “Add this website”. Click on **<Add>** to set IE to access the Volicon Media Intelligence service website in compatibility mode.

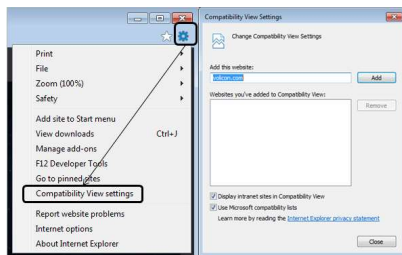

Figure: Setting IE compatibility view

- Next, set the location of the Volicon Media Intelligence service server as a trusted site. This enables the player to use ActiveX even if other IE settings restrict its use.
- From the same **<Tool>** icon used to set compatibility mode, select “Internet Options”. Select the **<Security>** tab and click on **<Trusted sites>**. Then click the **<Sites>** button. The Volicon Media Intelligence service website URL should be under “Add this website to the zone”. In our example, it is <http://obverv2.Volicon.com>. The IE default policy to allow placing a server in a trusted zone is that it must use SSL/TLS security (HTTPS). If the Volicon Media Intelligence service server does not use SSL/TLS, you need to uncheck the “Require server verification” checkbox. Press **<Add>** to update the trusted site list, then **<Close>**.
- To verify you successfully added Volicon Media Intelligence service, click **<Trusted sites>** again, then **<Sites>**. The Volicon Media Intelligence service server URL should show in the “Websites” box.

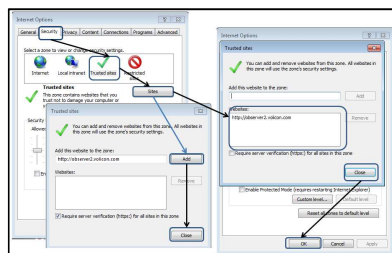

Figure: Add Volicon Media Intelligence service to IE trusted sites

---

## 10.3 Non-IE browsers support, clientless mode

Volicon Media Intelligence service supports a clientless mode for use with Firefox, Chrome, Edge and Safari browsers. Clientless mode allows you to avoid installing the ActiveX player. Volicon Media Intelligence service uses the Silverlight player when you use Firefox and HTML5 with Chrome/Edge/Safari. Note that Volicon Media Intelligence service supports the Safari browser only when using Safari on the Mac OS. Volicon Media Intelligence service does not support Safari on Windows.

## 10.4 Volicon Media Intelligence service ActiveX media player

When using IE to access Volicon Media Intelligence service, a customized ActiveX media player is required.

### 10.4.1 Installing the media player

When using IE the first time your computer connects to Volicon Media Intelligence service, you will be asked to install the ActiveX media player. This should take approximately 30 seconds.

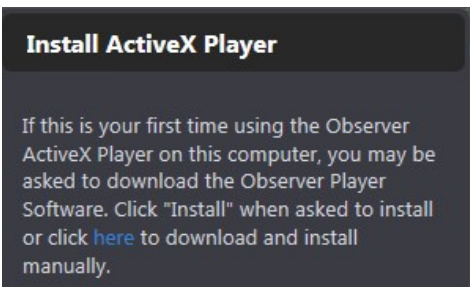

Figure: Request to install media player

---

#### Tech tip

Media player installation requires administrator rights on your PC.

---

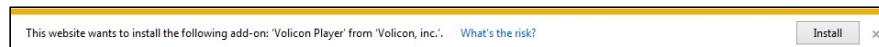

Figure: Windows security warning



Accept the warning by clicking **<Allow>**. This will launch the Volicon Media Intelligence service Media Player Setup Wizard.



Figure: Volicon Media Intelligence service Media Player Setup Wizard

If an older version of the Volicon Media Intelligence service media player has been installed, it will be removed automatically. Click **<Next>** to continue. Accept the terms of the License Agreement and click **<Next>** to continue.



Figure: License agreement

You have the option of choosing into which folder Volicon Media Intelligence service will install the media player. Unless a support engineer has instructed you otherwise, accept the default folder and click **<Install>**.

Internet Explorer must be shut down to install the media player. Log out of Volicon Media Intelligence service and shut down IE, then click **<OK>** to proceed.

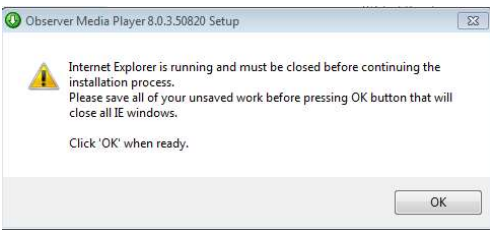

Figure: Shut IE down to install

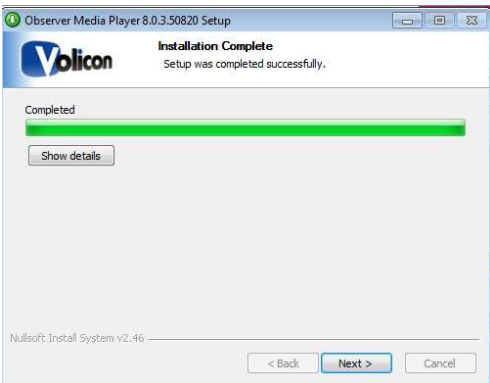

Figure: Player installation progress

#### 10.4.1.1 Optional settings

Volicon Media Intelligence service will present you with the “Optional settings” window.



Figure: Optional settings window

---

**Optional setting/selection:** Internet Explorer shortcut

If you want to add a quick connect button to your Internet Explorer toolbar, enter the URL or the IP address of the Volicon Media Intelligence service server in the field provided. Leave the field empty if you do not want Volicon Media Intelligence service on your toolbar.

**Optional setting/selection:** Intel video adapter workaround

Volicon Media Intelligence service recommends that if your computer has an older Intel video card, or a video card with an Intel chipset, you enable the Intel “flickering video” workaround checkbox as a precaution. Enabling the checkbox will not affect the performance of the Intel chipsets that do not have issues with multiple video streams; but it will protect you in the event that your chipset is one of those with known issues.

**Optional settings/selection:** Favor quantity over quality

Volicon Media Intelligence service also recommends that you check the “Enable favor quantity over quality” checkbox for the best experience using Internet Explorer to run multiple players.

Make your choices and click **<Next>**.

Volicon Media Intelligence service presents you with the “Completing the Volicon Media Intelligence service Media Player Setup Wizard” window.



Figure: Completing the Volicon Media Intelligence service Media Setup Wizard Window

Click **<Finish>** to exit setup.

---

## 10.4.2 Updating the media player

From time to time, you may receive notification that there is a new version of the player available. Follow the prompts and install the upgrade. You will be prompted to shut down IE to perform the install.

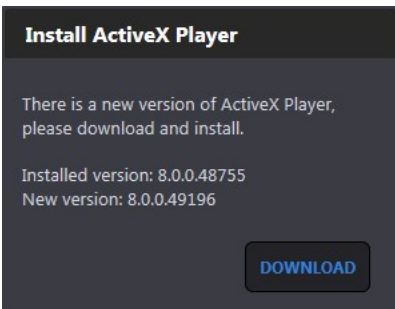

Figure: Update Volicon Media Intelligence service ActiveX media player

---

### Tech tip

Upgrading the player requires administrator rights, just like the initial installation

---

## 10.4.3 Removing the media player



To remove the media player, go to **<Control panel> → <Programs and features>** (Windows 7), then remove the “Volicon Media Intelligence service Media Player”.



Figure: Removing the media player

## 10.5 Volicon Media Intelligence service welcome page

The main action buttons are in the center of the screen.

- Your account name is displayed in the upper-right corner along with the session expiration time.
- If Volicon Media Intelligence service detects an idle session, it will time out and close the session.
- If the dashboard fault notification widget is enabled, a bell icon  appears to the right of the username. If there are active faults, the quantity is displayed in a red circle. Click the icon to display fault details.
- If Volicon Media Intelligence service is localized, use the dropdown  to the left of the gear icon to change the active language.
- Click the **<Gear>** icon  in the upper-right to log out or access Volicon Media Intelligence service management features.
- The main menu gives you access to the Volicon Media Intelligence service. As an Volicon Media Intelligence service administrator, you are primarily concerned with the **<Tool>** icon in the upper-right corner of the screen.

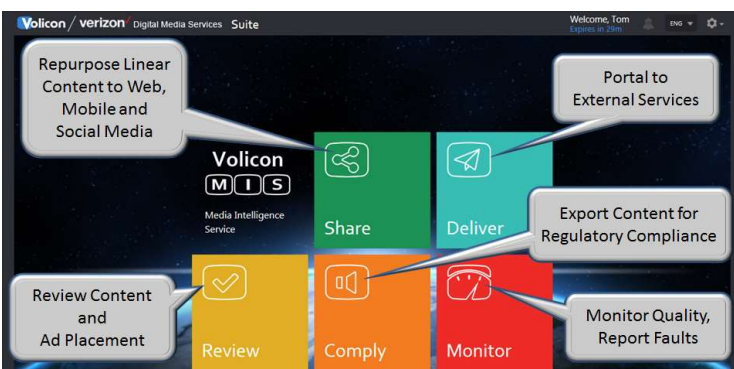

Figure: Welcome page

---

# 11 Volicon Media Intelligence service web-based configuration

Volicon Media Intelligence service configuration is web-based, save for a few specific exceptions. Your admin tools are a superset of the user tools. As an Volicon Media Intelligence service administrator, you have the ability to set which aspects of Volicon Media Intelligence service each user account is able to access.

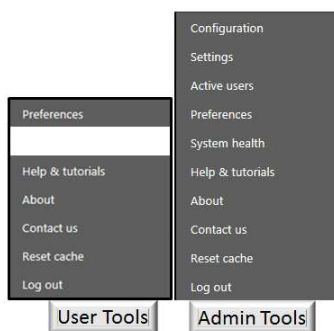

Figure: User vs. admin tool

- **Configuration** configures probe groups, probes and encoders.
- **Settings** configure the central server.
- **Active users** display a list of currently logged in users.
- **Preferences** have a user-specific setting and time zone.
- **System health** displays the status of various Volicon Media Intelligence service components.
- **Help & tutorials** link to embedded tutorials.
- **About** displays Volicon Media Intelligence service and ActiveX player version.
- **Contact us** links to Volicon Media Intelligence service support page.
- **Reset cache** clears all application caches, such as selected channels.
- **Log out** terminates the user session.

## 11.1 System architecture

The central server is the heart of the Volicon Media Intelligence service. It has an overarching responsibility for all aspects of the system. Depending on size, the Volicon Media Intelligence service will utilize one or more probe servers. The responsibility of the probe is to ingest and store programs. The probe utilizes capture cards to enable Volicon Media Intelligence service to interface with various program sources.

The Volicon Media Intelligence service probe ecosystem is organized in a hierarchal manner. There are several layers that make up the entire system: groups, probes and encoders.

- **Group(s):** This level associates multiple probes under one unified heading. Groups can be created by input source, geography, network capture location, etcetera.
- **Probe(s):** Each server, as a whole unit, contains anywhere from 1 to 16 video, audio and metadata capturing inputs/channels. It stores all the recorded content locally and streams out the recorded content to end users. A probe server contains one or more encoder streams or channels.
- **Encoder(s):** This is the proxy copy created for each item of video content recorded on the system. In the case of Volicon Media Intelligence service, it is a direct one-to-one relationship of each physical video input on the probe to the proxy stored on the probe.

You must assign each probe server in the system to a probe group. Use groups to help you organize your streams and manage alerts, since a probe group often shares a geographical territory or a specific service area.

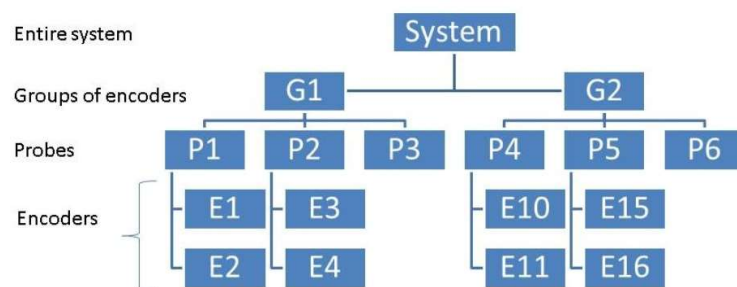





Figure: Probe architecture

## 11.2 Configuration: Probe groups

The probe configuration page contains two sections. The left-hand pane is the dashboard. It allows you to select the desired group or **<All>** groups. The right-hand pane provides a hierarchical view of the group, probes and individual encoders. In the dashboard to the right of each group is a number indicating how many probes and encoders are in the group.

At the top of the dashboard there are three icons that allow you to  create a new group,  rename a group and  delete a group. Below that is a text search bar in case there are a large number of groups.

Selecting a group displays the probes and encoders within the group. The +/- icons toggle the probe encoder display on/off. The color-coded check mark makes it easy to quickly determine the status of the probe and each encoder.

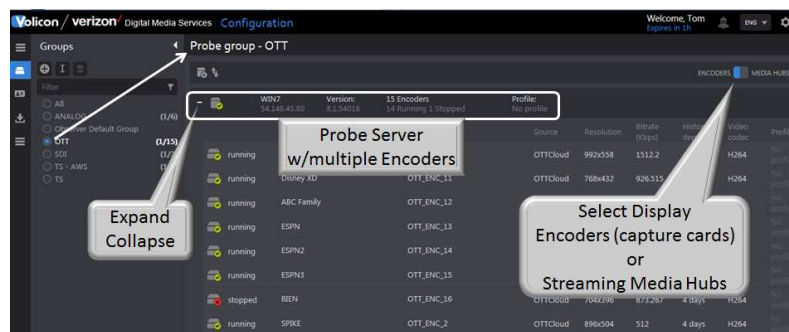



Figure: Probe groups

Probe status indicates if it is inaccessible  or running and accessible .

The status of each encoder is displayed in the text to the right of the name next to a color-coded icon (**green** checkmark: all is well, **red**: stopped).

Hovering anywhere on the probe line turns the background **blue** and displays five icons in the upper-right corner: **<Assign profile>**, **<Create & assign profile>**, **<Sync>**, **<Edit>** and **<Delete>**.



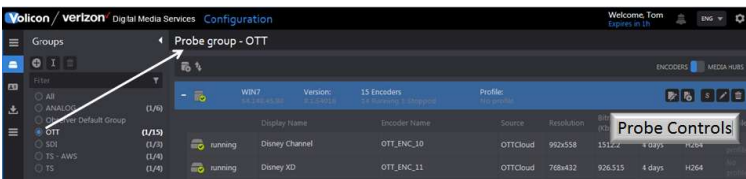



Figure: Probe controls

 **Assign profile** is a planned future feature.

 **Create and assign profile** is a planned future feature.

 **Sync** synchronizes the probe. A pop-up asks if you want to sync with **<Current>** or **<Previous>**. Selecting **<Current>** updates the probe with the changes you just made to its configuration. Selecting **<Previous>** allows you to revert to the old probe configuration. This comes in handy if the changes you made did not yield the desired results.

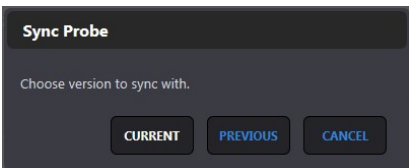



Figure: Probe sync

 **Edit probe** is the same as clicking on the probe name and opening the probe edit window.

 **Delete** removes the entire probe and only applies to empty groups when no probes have been assigned.

## 11.2.1 Create a probe group

The top of the “Groups” dashboard has three icons: **<Add>**, **<Rename>** and **<Delete>**. Selecting **<Add>** allows you to create and name an empty group. Once created, the next step is to assign one or more probe servers to the group.

To create a new probe group, press the **<Add>** icon to open the “Create probe group” dialog box. Type the desired name and press **<OK>**. Volicon Media Intelligence service will display confirmation at the top of the page once the probe group has been saved.

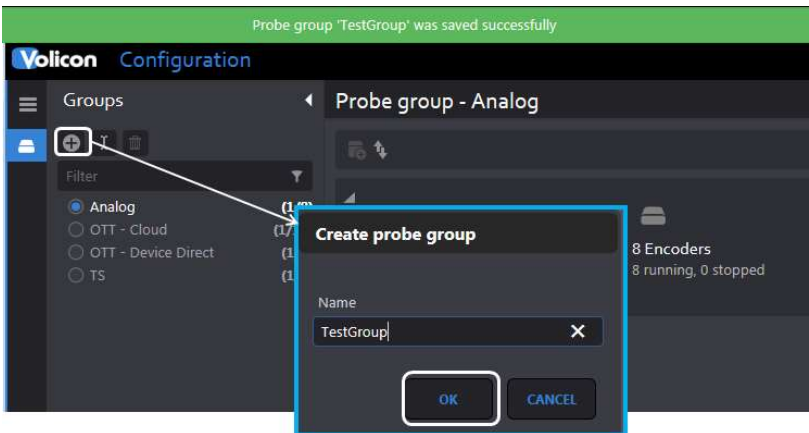

Figure: Create a probe group

To add probes to a probe group, select the desired group (in this example, the new TestGroup we just created) and press the **<Add>** icon at the top of the page. Enter the IP address of the probe in the right-hand pane and press **<Save>** at the bottom of the page. Do this for each probe you want to add to the probe group.

The profile entry feature is intended to simplify management of multiple probes.

Note: A probe may only be associated with a single probe group.

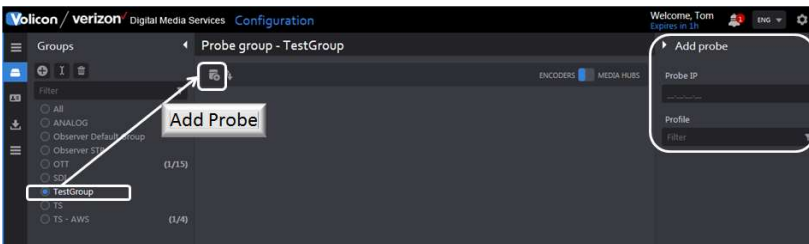

Figure: Assign probe to a probe group

### 11.2.2 Rename a probe group

This lets you rename the group. Select the group you want to rename and press the **<Rename>** icon at the top of the dashboard. A new dialog box will appear. Enter the new name and press **<OK>** to effect the change, or **<Cancel>** to keep the existing name. A message indicating the change was completed will momentarily appear at the top of the screen.

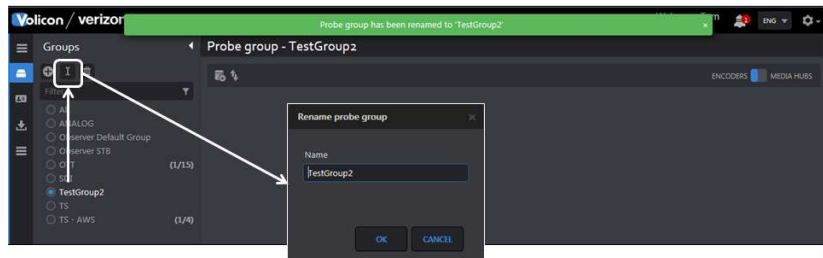

Figure: Rename a group

### 11.2.3 Delete a probe group

To remove a probe group, select the group to be removed and press the **<Trash>** icon. A dialog box will open to confirm the action. Press **<Delete>** to remove the group. Note: This simply removes the probe group; it does not affect the physical probe servers.

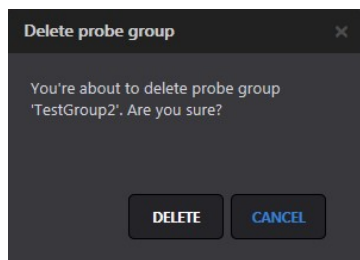

Figure: Delete probe group

### 11.2.4 Adding a probe

At the top of the page, to the right of the dashboard, are the **<Add probe>** and **<Expand/collapse>** icons. Volicon Media Intelligence service support is responsible for adding probes and encoders to the system. The **<Expand/collapse>** icon toggles the display between only probes and probes and encoders.

## 11.2.5 Editing a probe

Hovering over the desired probe highlights it in blue. The probe **<Edit>** icon at the upper-right of the page opens with four options: **<Probe>**, **<Streamer>**, **<NTPSERVICE>** and **<License>**.

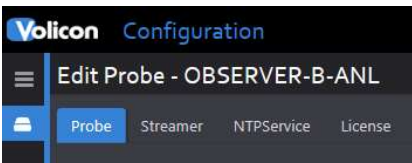

Figure: Edit probe

### 11.2.5.1 Edit probe: Probe section

The probe section is divided into three subsections: “General”, “Probe information” and “License information”.

#### **General:** Configurable probe fields

This subsection allows you to rename the probe, assign it to a different group and specify the LAN and WAN IP addresses of the probe server. Use the **<Probe group>** dropdown to assign the probe to a different group. If you want to assign the probe to a new group, you must first create an empty group using the dashboard.

The probe name was created by Volicon Media Intelligence service support when the probe was initially created and cannot be changed by the customer. To change the probe name seen by users, edit the “Display name” entry.

The probe IP address is normally set statically, but, optionally, dynamic addressing may be used via DHCP.

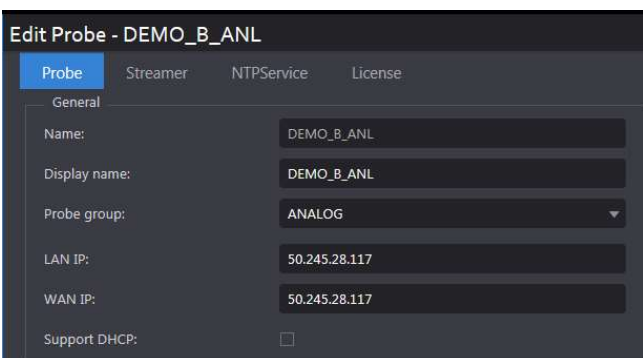

Figure: Configurable probe fields

#### **Probe status information**

---

This is a read-only status display.

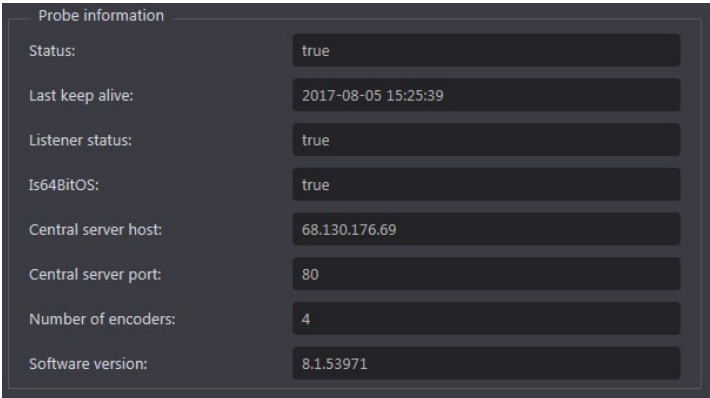

Figure: Accessible probe information display

If the probe is not accessible, the date of the last keep-alive is displayed.

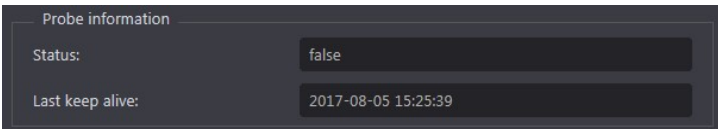

Figure: Inaccessible probe status

### Level license info

The bottom-most section is also read-only and displays licensing information.

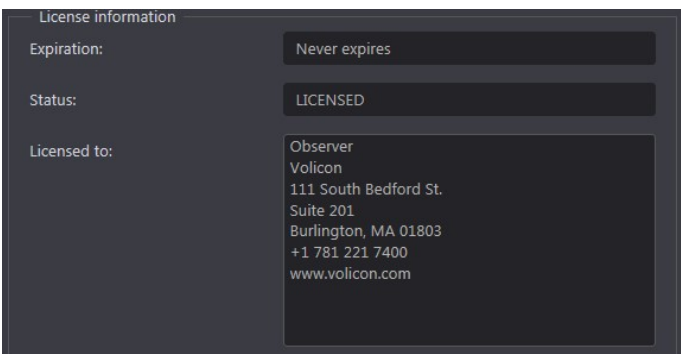
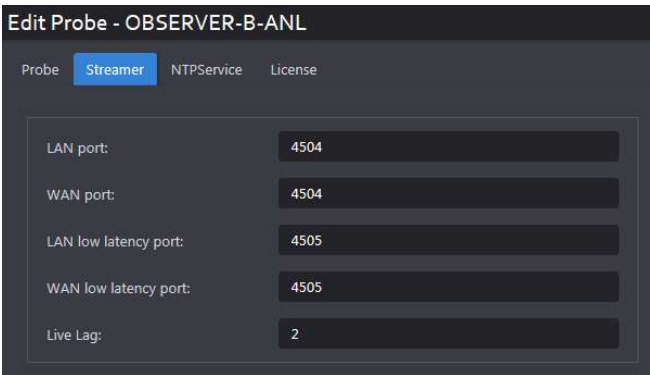

Figure: High-level license information

### 11.2.5.2 Edit probe: Streamer section

The “Streamer” section allows you to change the IP port values used to stream video. These should normally be left in their default settings.



The screenshot shows a configuration window titled "Edit Probe - OBSERVER-B-ANL". At the top, there are three tabs: "Probe", "Streamer", "NTPService", and "License". The "Streamer" tab is selected. Below the tabs, there are five input fields with their respective values:

Field	Value
LAN port:	4504
WAN port:	4504
LAN low latency port:	4505
WAN low latency port:	4505
Live Lag:	2

Figure: Streamer ports

### 11.2.5.3 Edit probe: NTPService section

Accurate timing is critical for successful Volicon Media Intelligence service operation. Many aspects of Volicon Media Intelligence service require millisecond-timing accuracy. This section allows you to change which network time protocol (NTP) time server Volicon Media Intelligence service uses and how often it is polled. Volicon Media Intelligence service defaults to the Microsoft NTP server defined in Windows.

In some cases, this setting is locked by Volicon Media Intelligence service. In that case, settings are read-only and  appear to the right of the polling interval and server.

1. If you run an internal corporate time server, change the configuration to point to it.
2. Another option is to use a NTP server pool. This has the advantage of redundancy, in which you can select geographically nearby servers to minimize transit time latency. The NTP Pool Project is popular and can be found at <http://www.pool.ntp.org/en/>.
3. A third option is to use the Windows operating system as preconfigured, pointing to the public Microsoft NTP server time.windows.com.

**Poll interval:** This setting is only active if the SpecialInterval flag is set.

Set the polling interval value to an integer, select the units from the **<Interval>** collection. Volicon Media Intelligence service recommends setting the polling interval to 3600 seconds.

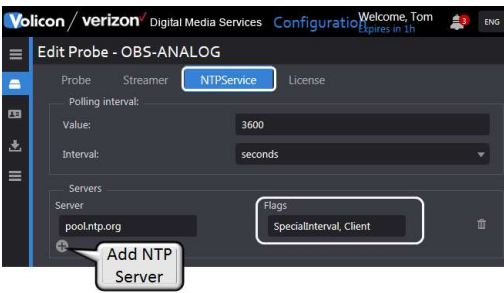

Figure: NTP time service

### NTP server

Enter the URL or IP address of the desired NTP server. Add additional servers for redundancy. If the active server throws an error or does not respond, Volicon Media Intelligence service will automatically switch to the next server on the list.

### NTP flags

In general, use the system defaults when adding NTP servers, unless instructed otherwise by Volicon Media Intelligence service support.

<b>SpecialInterval</b>	Normally W32Time (Windows Time service) will poll the remote NTP server on a floating interval based on the quality of the time samples being returned. Setting the SpecialInterval flag changes this behavior to a fixed static interval. Use the polling interval section to set the interval.
<b>UseAsFallbackOnly</b>	Setting this flag tells the time service to try the other time servers before using this one.
<b>SymmetricActive</b>	The host sends periodic messages regardless of the reachability state or stratum if its peer. The host announces its willingness to synchronize and be synchronized by the peer.
<b>Client</b>	The host sends periodic messages regardless of the reachability state or stratum if its peer. The host announces its willingness to be synchronized by, but not to synchronize, the peer.

Table: NTP flags

Once the server and flags are selected, use the **<Add server>** button to add the new NTP server. To delete a server, use the **<Delete>** button.

#### 11.2.5.4 Edit probe: License section

This read-only section displays each licensable feature and, where applicable, how many instances are allowed. Each feature consists of three entries: **allowed**, **configured** and **running**.

- **Allowed** indicates the maximum quantity authorized by the license. In instances where the feature is selectable to be either enabled or disabled, its corresponding value will be displayed as **YES** or **NO**.
- **Configured** indicates how many instances are currently configured.
- **Running** is a real-time display of the status of each feature.

<b>AC-3</b>	Dolby AC-3 audio channels
<b>AFD</b>	Active Format Description
<b>Closed-captioned indexing</b>	Monitoring closed captioning
<b>Detectors</b>	Specifies how many encoder detectors (video/audio/metadata) are allowed to run
<b>DolbyE</b>	How many encoders can be configured with DolbyE
<b>Extra audio streams</b>	Number of additional audio streams that can be configured in addition to main audio
<b>Full-res channels</b>	# of native uncompressed channels – counts to total limit
<b>HD channels</b>	# of HD channels – counts toward total channel limit
<b>Interactive services</b>	Scripting module for Interactive Services
<b>Long-term storage</b>	LTS option not subject to automatic purge
<b>Loudness measurement</b>	Monitor audio to insure it complies with FCC guidelines
<b>NAVE</b>	Nielsen Audio Video Encoder logging
<b>OTT channels</b>	# of over-the-top channels – counts toward total limit
<b>TS channels</b>	# of Transport Streams – counts toward total limit
<b>Total channels</b>	Absolute # of monitoring channels

Table: License details



## 11.2.6 Creating and editing encoders

Hovering over an encoder highlights the encoder in blue and displays four icons: **<Assign profile>**, **<Create and assign profile>**, **<Sync>** and **<Edit>**.

**Assign profile** is a future feature not implemented.

**Create and assign profile** is a future feature not implemented.

**Sync** updates the encoder with the latest configuration. As with probes, you have an option to sync to changes or revert to the previous configuration.

**Edit** accesses encoder-specific configuration details.

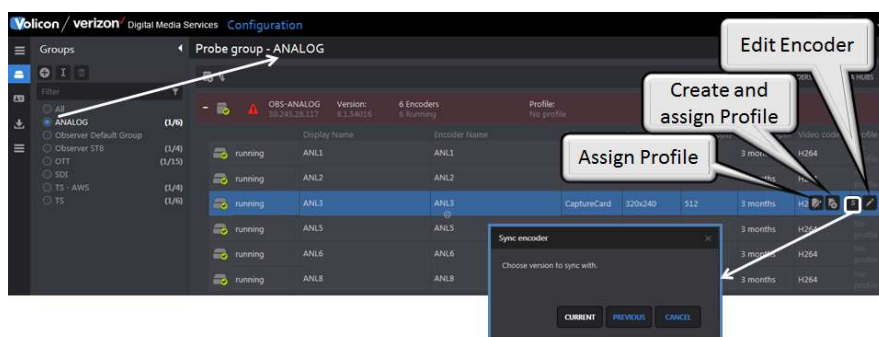

Figure: Syncing and editing an encoder

## 11.2.7 Adding an encoder

Volicon Media Intelligence service Support is responsible for installing probes and encoders.

## 11.2.8 Encoder configuration

Press the **<Edit>** icon to access details about the encoder.

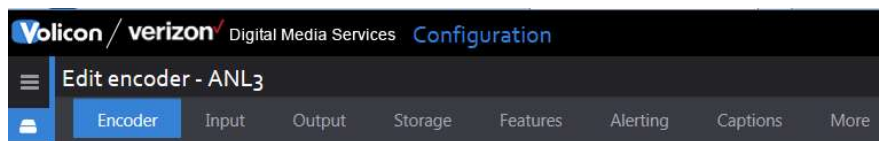

Figure: Encoder sections

---

Each encoder has eight configuration subsections.

- **Encoder** configures specifics of name and display icons.
- **Input** programs ingest settings.
- **Output** configures specifics of how Volicon Media Intelligence service stores each channel and sub-encoders.
- **Storage** configures storage location and duration.
- **Features** enable loudness, thumbnails and NAVE.
- **Alerting** sets error detection thresholds.
- **Captions** configure CC and subtitles.
- **More** configures miscellaneous settings.

At the bottom of each page is a **<Save>** button. Volicon Media Intelligence service will prompt you to save changes if you attempt to leave the section without saving changes.

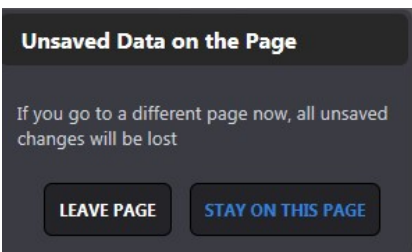

Figure: Unsaved change warning

### 11.2.8.1 Encoder

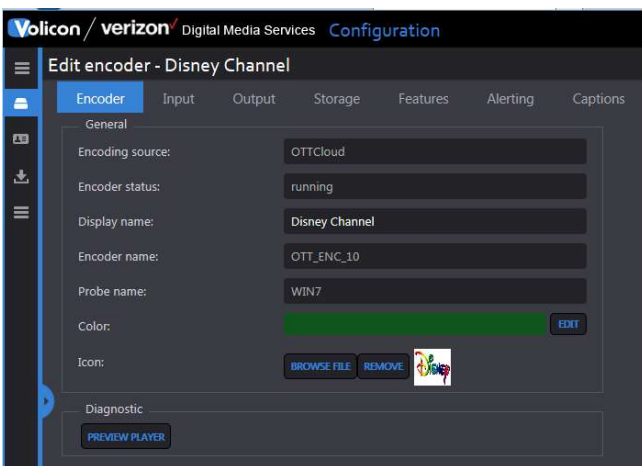

Figure: Encoder settings

<b>Encoder source</b>	Indicates which of the four possible input types is use – video capture card, Transport Stream, cloud or device direct
<b>Encoder status</b>	Real-time encoder status – running or stopped
<b>Display name</b>	Encoder name presented to users; used to create a user-friendly name for the channel
<b>Encoder name</b>	Read-only name created by Volicon Media Intelligence service
<b>Probe name</b>	Probe server on which the encoder is installed
<b>Color</b>	Dropdown used to color code the player
<b>Icon</b>	Used to add an icon to channel name; <b>&lt;Browse file&gt;</b> icon used for workstation access to upload desired icon; typically for uploading channel logo, but may be any JPG or PNG image
<b>Diagnostic</b>	Opens media player for the channel

Table. Encoder information

### 11.2.8.2 Encoder: Input

This section is dependent on how the program is ingested by the Volicon Media Intelligence service. Currently, there are four types of video acquisition.

- **Video input:** Capture card used to interface Volicon Media Intelligence service to program source
- **Transport Stream (TS):** IP-based direct program access
- **Cloud:** IP-based, typically via CDN streaming
- **Device direct:** Tethered cell phone acquisition

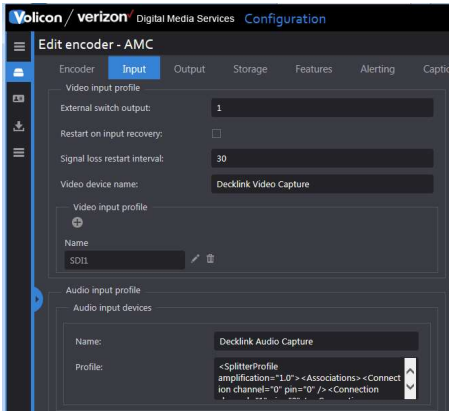

Figure: Encoder capture card Transport Stream input profile

<b>External switch output</b>	If external A/V switch used, entry specifies which switch output port feeds associated encoder input, assuming switch has more than one output port; set value to 1 if external input switch not used
<b>Restart on input recovery</b>	Automatically restarts encoder when its input is recovered; relevant for Blackmagic cards only to avoid timestamp issues
<b>Signal loss restart interval</b>	During periods of no input, encoder automatically restarts at specified interval to avoid time stamp issues
<b>Video device name</b>	Text string with the card name and channel ID if the card supports multiple channels
<b>Name</b>	Required text field
<b>Connector type</b>	Dropdown used to select video connector
<b>Format</b>	Dropdown used to select type (i.e., PAL-B 1080i, frame rate and resolution)
<b>Add format</b>	Used to open dialog to create another format

Table: Video input profile (capture card and Transport Stream)

<b>Name</b>	Card name and additional information about audio input type
<b>Profile</b>	Audio profile in XML format

Table: Audio input profile (capture card and Transport Stream)

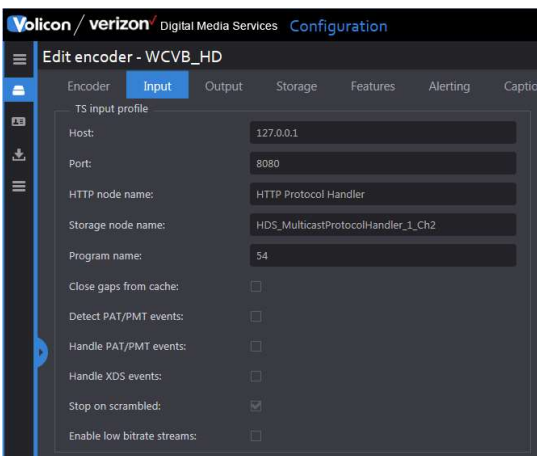

Figure: Encoder Transport Stream IP ingest section

<b>Host</b>	IP address or URL of the program source
<b>Port</b>	IP port address to access the program
<b>HTTP node name</b>	The name of the HTTP node, as configured in the Mediahub, for streaming data of the required PID
<b>Storage node name</b>	The name of the storage node, as configured in the Mediahub, where data for the required PID is stored
<b>Program name</b>	The name of the program to encode the TS stream
<b>Close gaps from cache</b>	If encoder losses feed, it keeps recording black screen until feed returns; allows downtime to be represented in the recorded data
<b>Detect PAT/PMT events</b>	Deprecated, no longer used
<b>Handle PAT/PMT events</b>	Deprecated, no longer used
<b>Handle XDS events</b>	System to process Extended Data Services events and log them
<b>Stop on scrambled</b>	Ignores encrypted streams so Volicon Media Intelligence service does not generate erroneous alerts
<b>Enable low-bitrate streams</b>	Enable/disable handling of low-bitrate streams; usually disabled due to slowing down of recovery in event of connection loss; to be enabled if nearly no payload (e.g., black video); this should be enabled

Table: TS input profile (IP ingest section)

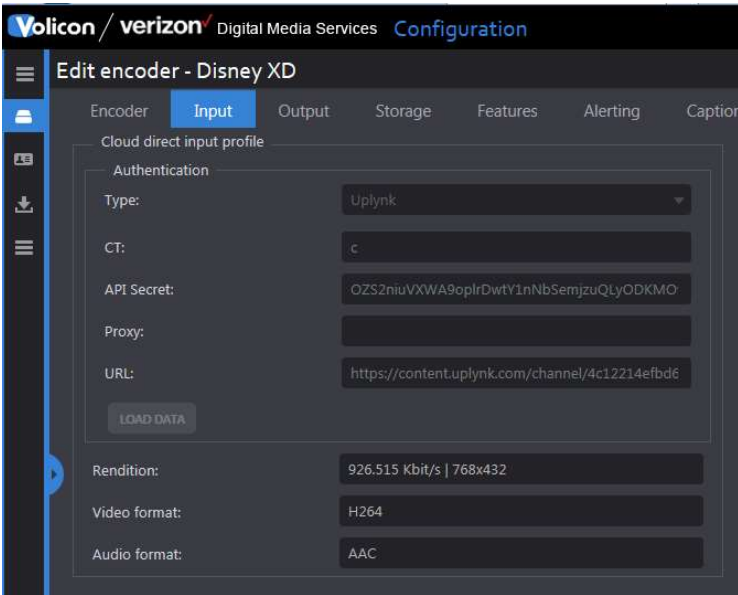

Figure: Encoder cloud input

<b>Type</b>	Dropdown used to select program source server – no Authentication, Akamai, Uplynk CMS
<b>ACL</b>	Akamai parameter
<b>Shared key</b>	Akamai parameter
<b>CT</b>	Uplynk parameter
<b>API secret</b>	Uplynk parameter
<b>Proxy</b>	URP or IP of proxy server if used
<b>URL</b>	Channel-specific URL
<b>Load data</b>	Saves profile data
<b>Rendition</b>	Bitrate and resolution
<b>Video format</b>	Normally set automatically based on the input feed, but may be sent manually
<b>Audio format</b>	Normally set automatically based on the input feed, but may be sent manually

Table: Cloud direct input profile

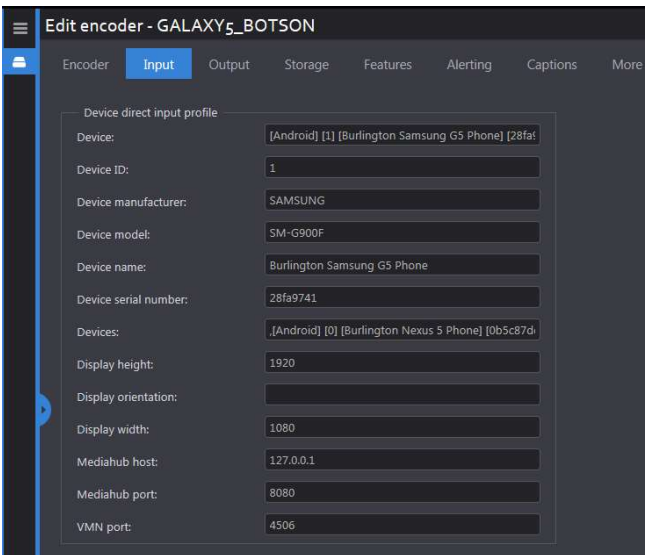

Figure: Encoder device direct input

<b>Devices</b>	Smartphone used to capture the program
<b>Device ID</b>	ID of the device as the MediaHub configured it
<b>Device manufacturer</b>	Smartphone manufacturer
<b>Device model</b>	Smartphone model name
<b>Device name</b>	The name of the device to be shown in MediaHub
<b>Device serial number</b>	The hardcoded serial number of the device; automatically detected
<b>Devices</b>	A list of all devices connected to the server
<b>Display height</b>	Height in pixels
<b>Display orientation</b>	Landscape or portrait; if blank, defaults to portrait
<b>Display width</b>	Width in pixels
<b>Mediahub host</b>	Mediahub IP address typically localhost
<b>Mediahub port</b>	IP port typically 8080 to avoid conflicting with other web servers
<b>VMN port</b>	Port used to stream content from the device

Table: Device direct input profile

### 11.2.8.3 Encoder: Output

Unlike inputs, the output settings are the same for all encoders, regardless of how the program is ingested into Volicon Media Intelligence service.

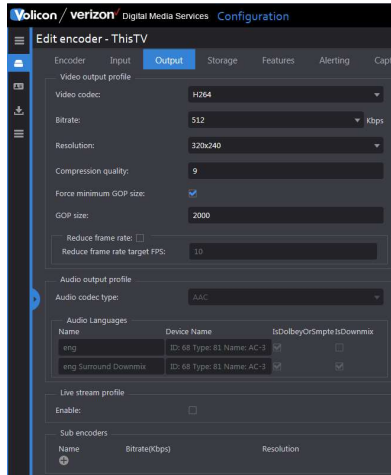

Figure: Encoder output

<b>Video codec</b>	Dropdown used to specify how Volicon Media Intelligence service encodes the program for storage; Volicon Media Intelligence service supporting H264, WMV3, WMVA and WVC1
<b>Bitrate (Kbps)</b>	Dropdown used to specify program bitrate for storage
<b>Resolution</b>	Dropdown used to specify screen resolution for storage
<b>Compression quality</b>	
<b>Force minimum GOP size</b>	Optional field to set MPEG group of picture structure; setting defines amount of frames dependent on preceding frame before another I frame; MPEG removes redundancy spatially within a frame and temporally among frames; I frame (or key frame) - the only frame that can be decompressed without reference to other frames
<b>Reduce frame rate</b>	Reduces frame rate to reduce output bandwidth consumption
<b>Reduce frame rate target FPS</b>	Output frame rate value

Table: Video output profile



<b>Audio codec type</b>	Dropdown used to specify how Volicon Media Intelligence service encodes audio for storage: AAC, WMA and WMApro; when configuring audio codec type that describes the audio codec used by this encoder, codec changed for each audio stream in feed
<b>Audio languages</b>	Specifies one or more audio channels

Table: Audio output profile

<b>Enable</b>	Live stream used to view low-latency video on monitor page; note that this feature CPU intensive
---------------	--

Table: Live stream profile

**Sub encoders**

Each encoder has a primary video codec that creates the channel stream digital multimedia archive. If desired, additional sub encoders may be configured. Sub encoders are typically set for lower resolution and bitrate, in comparison to the primary codec that serves specific monitoring or file exchange requirements.

Sub encoders have the same server requirements as the identical setting for the primary codec sequentially; CPU cycles are needed for the compression engine, and disk storage is needed for the resulting file.

<b>Name</b>	System-created name derived from bitrate and resolution
<b>Bitrate (Kbps)</b>	Drop-down selection of bitrates
<b>Resolution</b>	Drop-down selection of screen resolution
<b>Add/delete</b>	Adds or deletes a sub encoder

Table: Sub encoders

#### 11.2.8.4 Encoder: Storage

This section defines where video is stored, how long it is saved and the disk threshold.

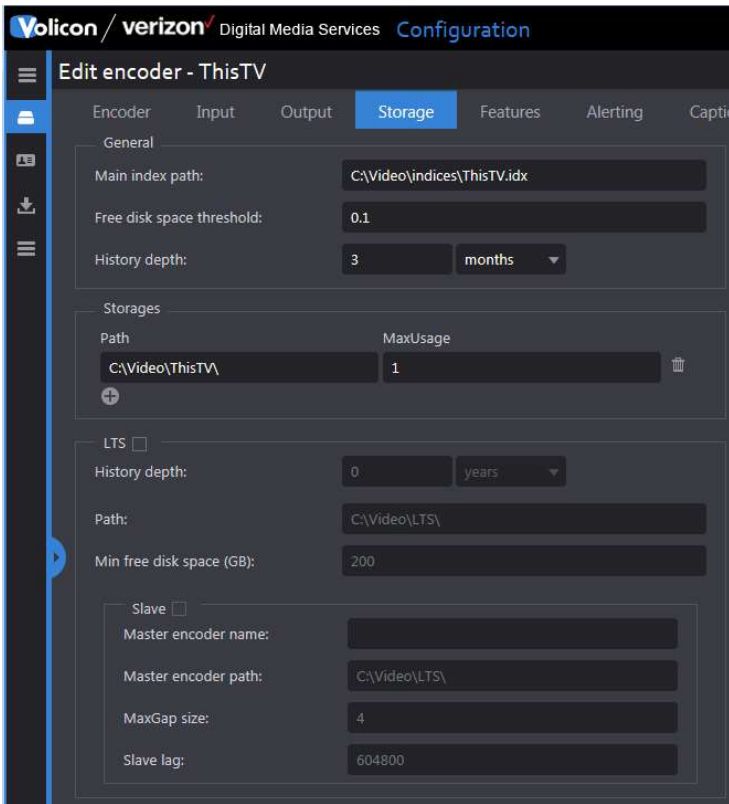

Figure: Encoder storage

<b>Main index path</b>	Example: C:\Video\indices\AB1.idx; normally set by Volicon Media Intelligence service to default path on main HDD
<b>Free disk space threshold</b>	Amount of space not to be used by Volicon Media Intelligence service, but kept free for other use; value to be 0-0.9, where 0 means no free space reserved, and 0.9 means 90% of storage location kept free
<b>History depth</b>	Specifies how long programs are stored; numeric value specifying how many unit intervals video will be stored; e.g., value of 30 and interval of days will store video 30 days

Table: Storage information

<b>Path</b>	Absolute path to the storage location
<b>MaxUsage</b>	The maximum percentage of the total size of the storage location used by the channel
<b>Add/delete</b>	Add/remove storages

Table: Storages

<b>History depth</b>	Specifies duration of program storage; streams normally stored in local storage; if inadequate, Volicon Media Intelligence service support to configure LTS; numeric value of unit intervals video will be stored: dropdown specifying minutes, hours, days, weeks, months, years; setting value to 0 means data not saved
<b>Path</b>	LTS storage location; typically C:\Video\LTS\ if LTS is running on the same computer
<b>Min free disk space</b>	Minimum disk space available on archive machine before archiving; value is in Gigabytes
<b>Slave</b>	Specifies if this encoder is a backup encoder for another system
<b>Master encoder name</b>	The name of the master encoder; only relevant when backup encoder is used
<b>Master encoder path</b>	Absolute path to the storage location of the master encoder; only relevant when backup encoder is used
<b>MaxGap size</b>	The maximum gap size between files
<b>Slave lag</b>	Specifies how long slave will wait before starting to archive its content; setting to less than one week not recommended - may cause master and slave to archive needlessly

Table: Long-term storage (LTS)

### 11.2.8.5 Encoder: Features

This section specifies audio loudness monitoring, DPI and AFD metadata processing, thumbnails and NAVE.

## 11.2.8.6 Loudness monitoring

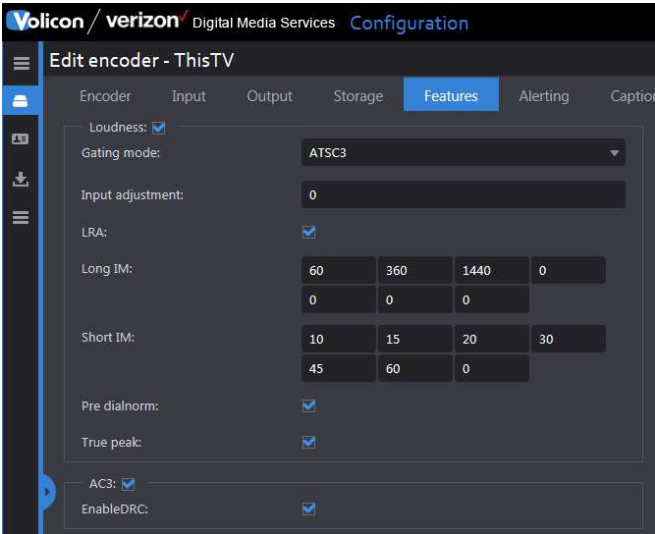

Figure: Encoder features – loudness

<b>Loudness</b>	With optional loudness module enabled, Volicon Media Intelligence service performs loudness meter measurements to meet following standards: EBU R 128, BS-1770-1, BS-1770-3, ATSC A/85 and EBU Tech 3341/2/3; Volicon Media Intelligence service loudness module, accurate per each video frame, takes measurements every 100 milliseconds; measurements able to be done with/without gating windows (-10 dB but adjustable)
<b>Gating mode</b>	Dropdown used to select ATSC1, ATSC3 or EBU
<b>Input adjustment</b>	Adjustment to input level for fine tuning; a floating-point value will be added to the input measurement
<b>LRA</b>	Loudness Range Measurement (LRA) quantifies variation in time-varying loudness measurement; supplementary to main audio measure, program loudness, of EBU R 128; measures variation of loudness on macroscopic time-scale loudness units (LU); LRA computation based on measurement of loudness level specified in ITU-R BS.1770 - with different gating threshold; LRA not to be confused with other measures of dynamic range

<b>Long IM</b>	Long-form Integrated Measurements: Greater than two minutes; total of seven user-defined, configurable measurements (e.g., 1 hour, 6 hour, 1 day, 5 day intervals); long-term values Volicon Media Intelligence service default setting: 60, 360, 1440, 0, 0, 0, 0
<b>Short IM</b>	Short-form Integrated Measurements: Two minutes or shorter; total of seven user-defined, configurable measurements (e.g., 10s, 30s, 60s); short-term values Volicon Media Intelligence service default setting: 10, 15, 20, 30, 60, 120, 0
<b>Pre-dialnorm</b>	Dialnorm indicates level of average spoken dialogue within encoded audio program; short-, long-term values often factory preset; Dialnorm not to be enabled when encoder ingesting digital audio stream (e.g., optical, S/PDIF or Dolby AC-3)
<b>True peak</b>	Enables monitoring the value of the audio signal waveform of a program in the continuous time domain; detects peak loudness that otherwise would escape the sampling process

Table: Loudness monitoring

<b>AC-3</b>	Dolby: Adaptive Transform Acoustic Coding 3 enable/disable
<b>Enable DRC</b>	Dolby: Dynamic Range Compression

Table: AC-3

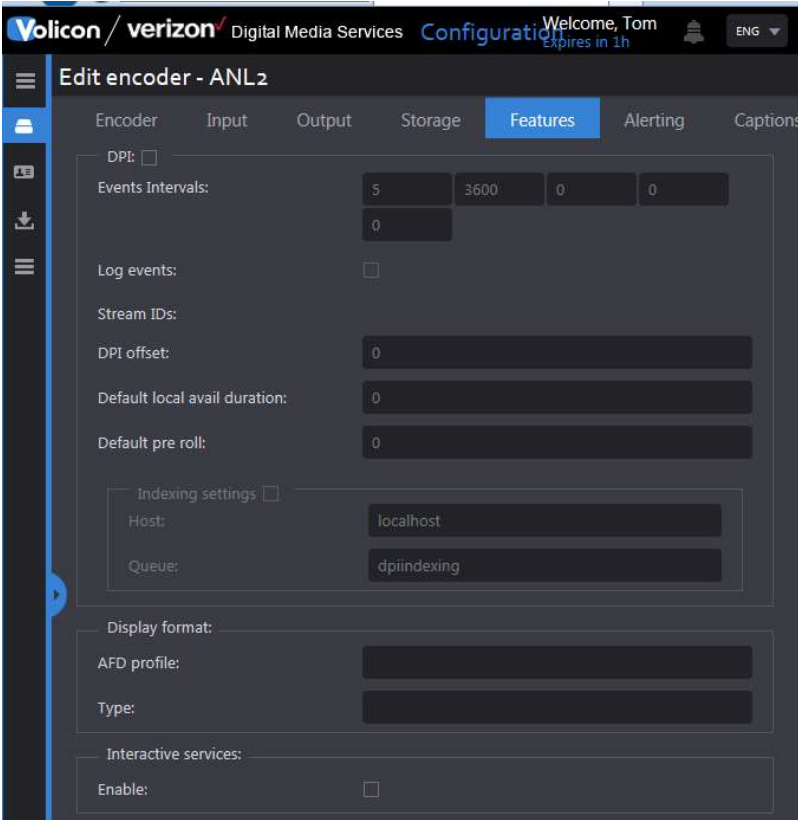

Figure: Encoder features – DPI and AFD

<b>DPI</b>	Digital Program Insertion
<b>Events interval</b>	List of intervals to be monitored for in/out DPI events
<b>Log events</b>	Enable/disable logging of DPI event to a database
<b>Stream IDs</b>	List of DPI streams to be monitored
<b>DPI offset</b>	Offset of DPI event relative to A/V (in milliseconds)
<b>Default local avail durations</b>	Default location available duration to use (in milliseconds)
<b>Default pre-roll</b>	Default pre-roll time before local avail (in milliseconds)
<b>Indexing settings</b>	New feature not yet implemented

Table: Digital Program Insertion (DPI)

<b>AFD profile</b>	AFD profile in XML format
<b>Type</b>	Not used in Volicon Media Intelligence service

Table: Active Format Description (AFD)

<b>Enable</b>	Only applies to RPM systems: Identify objects and images on screen; used for channel change verification
---------------	--

Table: Interactive services

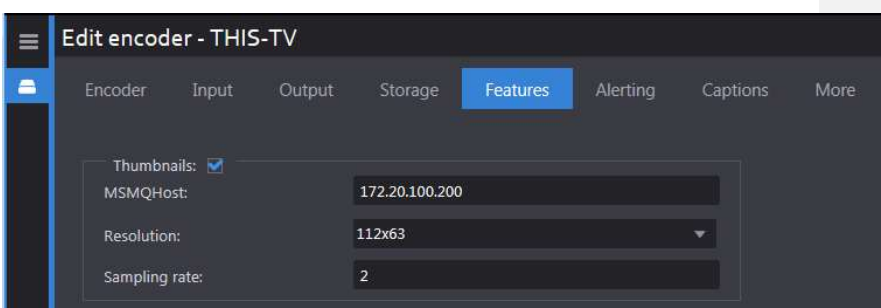

Figure: Encoder features – thumbnails

<b>Thumbnails enable</b>	Checkbox to enable/disable thumbnails
<b>MSMQHost</b>	IP address or URL of Microsoft Message Queuing used to access video clip thumbnails
<b>Resolution</b>	Dropdown used to specify thumbnail image resolution
<b>Sampling rate</b>	Every x seconds, saves an image to storage

Table: Thumbnails

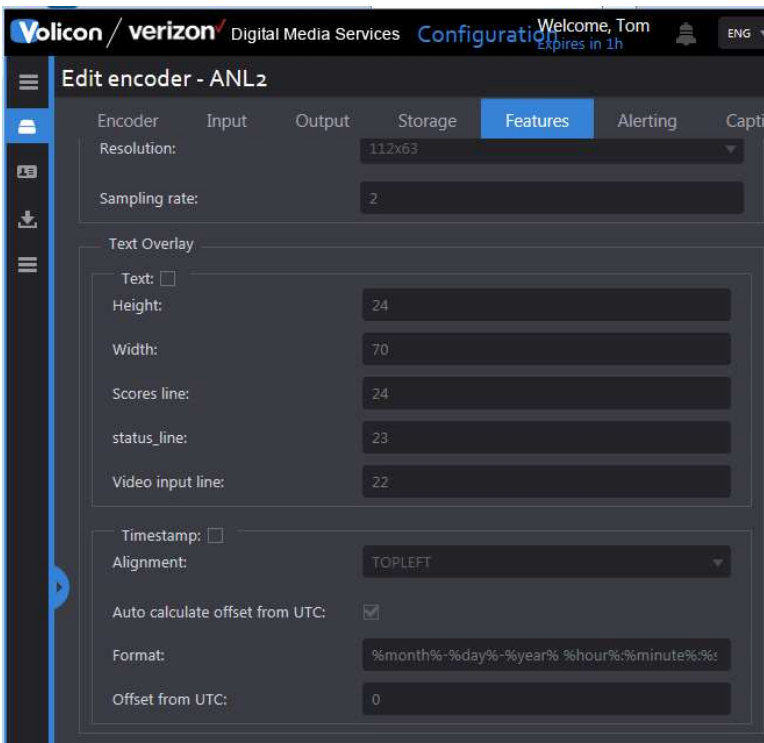

Figure: Encoder features – text overlay

<b>Text</b>	Enable/display of embedded text
<b>Height</b>	Number of free text lines
<b>Width</b>	Number of characters in a free text line
<b>Score line</b>	The line on which the scores will be burnt in a 1-based index system
<b>Status line</b>	Line on which scores to be burnt in 1-based index system; if using default height, this is line before last
<b>Video input line</b>	Setting for the video input line burnt into the video

Table: Text overlay



<b>Timestamp enable</b>	Turns on timestamp overlay for this encoder channel
<b>Alignment</b>	Dropdown used to position the info on player screen
<b>Auto calculate offset from UTC</b>	Based on probe's time setting
<b>Format</b>	Specifies how time is displayed: %month%-%day%-%year%%hour%:%minutes%:%second%/frame%
<b>Offset from UTC</b>	Manually sets a time zone offset; setting overrides probe O/S time zone setting; Volicon Media Intelligence service uses value instead of offset in probe

Table: Timestamp

### 11.2.8.7 NAVE

Encoding of television signals, such as in the Nielsen system, is used for audience measurement (e.g., to accurately identify television distributors, including broadcast stations or cable networks). The Nielsen Media approach installs metering devices at the user's premises. This device identifies stations and networks to which the end user tunes in. By encoding content with a NAVE unit, ratings data for programming can be provided – whether it is received in a digital, analog or combined viewing environment. Reading the aforementioned watermarks, or other codes, inserted into the television signal at the distribution source through the NAVE unit captures this end user data.

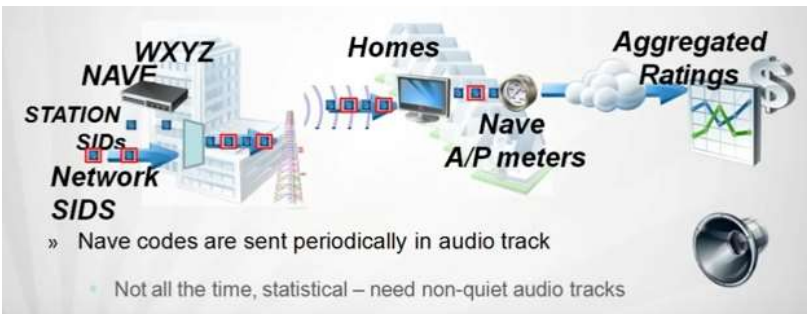

Figure: NAVE watermarking

The NAVE is a system capable of inserting Nielsen Media Research proprietary NAVE source identification watermarking directly into the audio portion of compressed digital ATSC Transport Streams prior to broadcast. NAVE devices can simultaneously insert watermarking data on multiple independent digital television programs being broadcast, whether they are standard-definition (SDTV) or high-definition (HDTV). The watermark is

capable of identifying the Provider Content (PC), the network on which the content was distributed (NT) and the final distributor (FD), say in the case of local broadcast station or cable channel. The watermarks include a timestamp, so if the content viewed is time-shifted (VOD) within a reasonable time frame, that usage data is also captured.

If any station's NAVE encoder is interrupted, the meter device installed in Nielsen sample premises collects and stores passive signatures for all non-encoded programming viewed. These signatures are downloaded each night to Nielsen's operations center. To identify viewing, the passive signatures collected from the meter device in the premises are matched against the signatures in the library.

The feature allows you to define the watermarks to be accepted, and the faults/recoveries to occur, by configuring the watermark's creation time and the number of good watermarks that should be received per period.

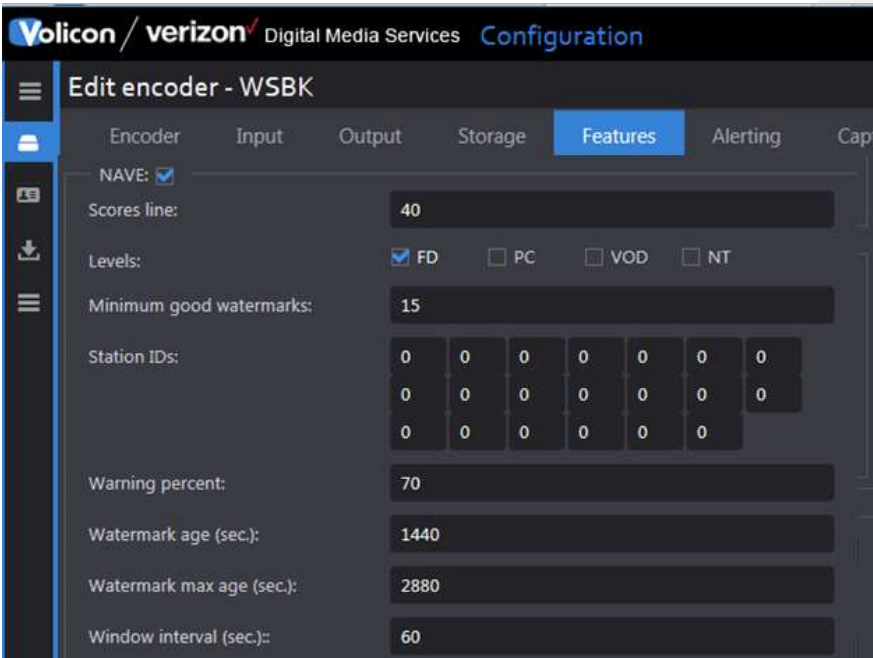

Figure: Encoder features – NAVE

<b>Enable</b>	Enable/disable Nielsen Audio Video Encoder monitoring; requires a subscription to Nielsen service
<b>Score line</b>	Percentage of good watermarks in the monitored window; labeled "Error percent" in early versions of Volicon Media Intelligence service
<b>Levels</b>	Filters watermarks by their levels
<b>FD</b>	Final Distributor: Entity that delivered content to customer
<b>PC</b>	Provider Content: Entity that originated content
<b>VOD</b>	Video on Demand: Time-shifted viewing
<b>NT</b>	Network that delivered the content
<b>Minimum good watermarks</b>	If number of good watermarks during sliding window are lower than minimum value, fault detected
<b>Station IDs</b>	List of good watermarks you intend to accept; if field left empty, all watermarks will be detected; if some channels support more than one station ID (SID), insert into SID array all IDs you intend to accept; single SID sufficient to satisfy <i>minimum good watermarks</i> and <i>watermark percentage recovery</i> variables to avoid faults and stay recovered
<b>Warning percent</b>	If value greater than score line but less than warning percent, warning message will be sent; other cases to result in recovery
<b>Watermark age</b>	The watermark's time from its creation
<b>Watermark max age</b>	Filters out watermarks older than threshold and reports no faults on these; if left at 0, variable watermark age taken; e.g., if watermark is 10 days old, any older watermarks to be ignored; if the watermark's age is less than threshold, it will be processed as regular watermark
<b>Window interval</b>	Faults detected and recoveries enabled during sliding window interval; e.g., if you define 30-second window for each second, 30-second window will be checked (0-30, 1-31, 2-32...) against various parameters used

Table: NAVE

### 11.2.8.8 Encoder: Alerting

The alerting feature configures Volicon Media Intelligence service to constantly monitor program streams. If the stream does not meet the monitoring criterion for the duration specified, an alert is generated. A single alert is dispatched for each event. If the stream returns to normal in excess of the recovery time, a new alert is generated if the stream once again falls outside monitoring parameters.

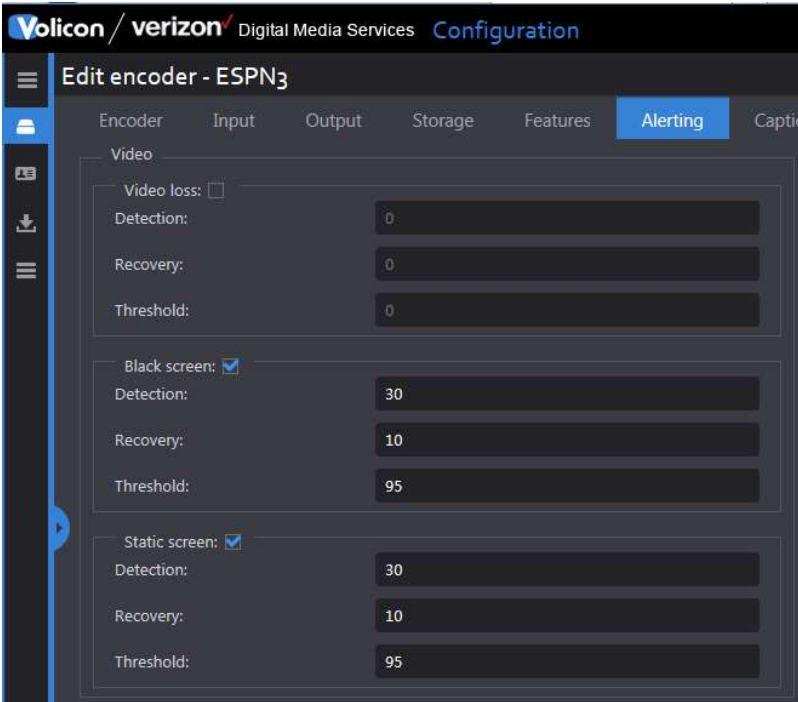

Figure: Encoder alerting video

<b>Video loss</b>	When video framing loss (commonly known as “sync”) is detected by hardware and persists over video duration threshold, then VIDEOLOST alert generated; only duration threshold is configurable, not level threshold; e.g., video lost signal = TRUE over duration of 31 sec exceeding cycle time and duration threshold; when notification enabled, SNMP trap and email messages are sent (if configured by admin)
<b>Detection</b>	Default: 30 seconds
<b>Recovery</b>	Default: 10 seconds
<b>Black screen</b>	When percentage of black pixels (BS) in video frames of incoming video signal exceeds certainty threshold and persists over duration threshold; when notification enabled, SNMP trap and email messages are sent (if configured by admin)
<b>Detection</b>	Default: 30 seconds
<b>Recovery</b>	Default: 10 seconds
<b>Threshold</b>	Default: 95%
<b>Static screen</b>	Detected when video frame pixels at same frame location are compared (for color and luminosity) to pairs of consecutive video frames; and percentage of matching pixels exceeds static screen (SS) threshold and duration threshold; when pixel color, luminance and locations matching between pairs of consecutive video frames exceed 95% of all video frame pixels for longer than 30 seconds, video static alert is declared  When notification enabled, SNMP trap and email messages are sent (if configured by the admin)
<b>Detection</b>	Default: 30 seconds
<b>Recovery</b>	Default: 10 seconds
<b>Threshold</b>	Default: 95%

Table: Video alerting

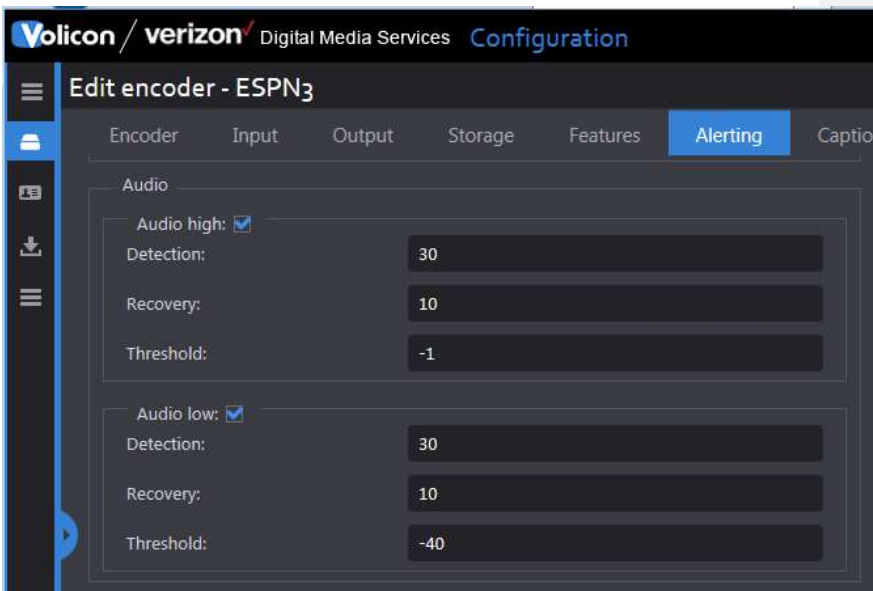

Figure: Encoder alerting audio

## Audio high

Audio high fault is detected when the incoming audio stays above the high-level threshold long enough to exceed the audio duration threshold.

**Audio high alert example:** Audio alert is configured on a channel. Certainty threshold = -1 dB; duration set to default of 30 seconds; audio input signal detected = 2 dB (above certainty) for six minutes (exceeding the cycle time for the lineup plus the duration threshold). A media fault, therefore, is detected, generating an audio alert and automatically creating a fault clip, which is stored under the clips (fault clips section on the Volicon Media Intelligence service media player).

When the notification is enabled, SNMP trap and email messages are sent (if configured by the admin).

If you wish to change any certainty, duration or recovery levels, please contact Volicon Media Intelligence service Support.

### Detection

The default is 30 seconds.

### Recovery

The default is 10 seconds.

<b>Threshold</b>	The threshold is -1dB.
<b>Audio low</b>	<p>Low audio fault is detected when the incoming audio stays below the low-level threshold, and the duration of the fault exceeds the duration threshold. Disable audio alert detection on channels with frequent silence.</p> <p>When the notification is enabled, SNMP trap and email messages are sent (if configured by the admin).</p>
<b>Detection</b>	The default is 30 seconds.
<b>Recovery</b>	The default is 10 seconds.
<b>Threshold</b>	The default is -40dB.

Table: Audio alerting

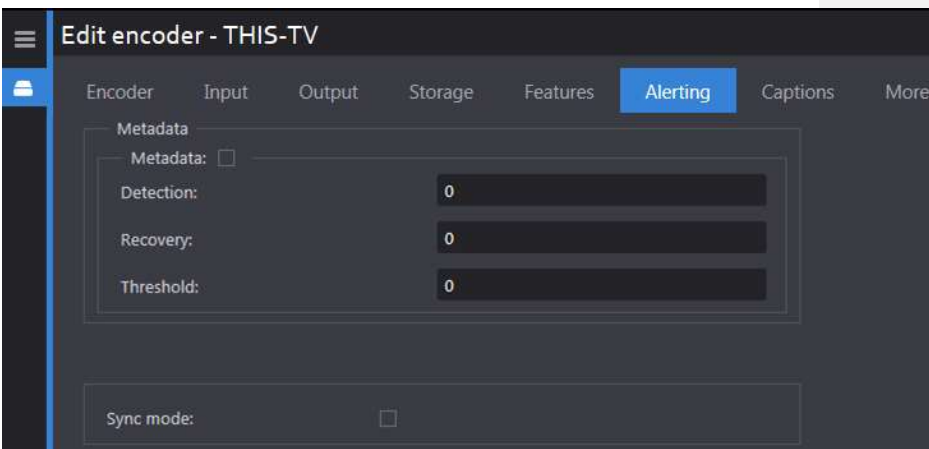

Figure: Encoder alerting metadata

<b>Metadata</b>	Monitors embedded channel metadata
<b>Detection</b>	Default: 30 seconds
<b>Recovery</b>	Default: 10 seconds
<b>Threshold</b>	Defines number of metadata instances missed in detection threshold duration; e.g., if threshold set to 5, and more than 5 instances missed during 30-second window, then alert generated

Table: Metadata alerting

### Sync mode

Determines how quickly NTP sync will compensate for real-time clock drift

Table: Sync

### 11.2.8.9 Encoder captions: Closed captioning

This section determines how Volicon Media Intelligence service processes closed captioning and subtitles.

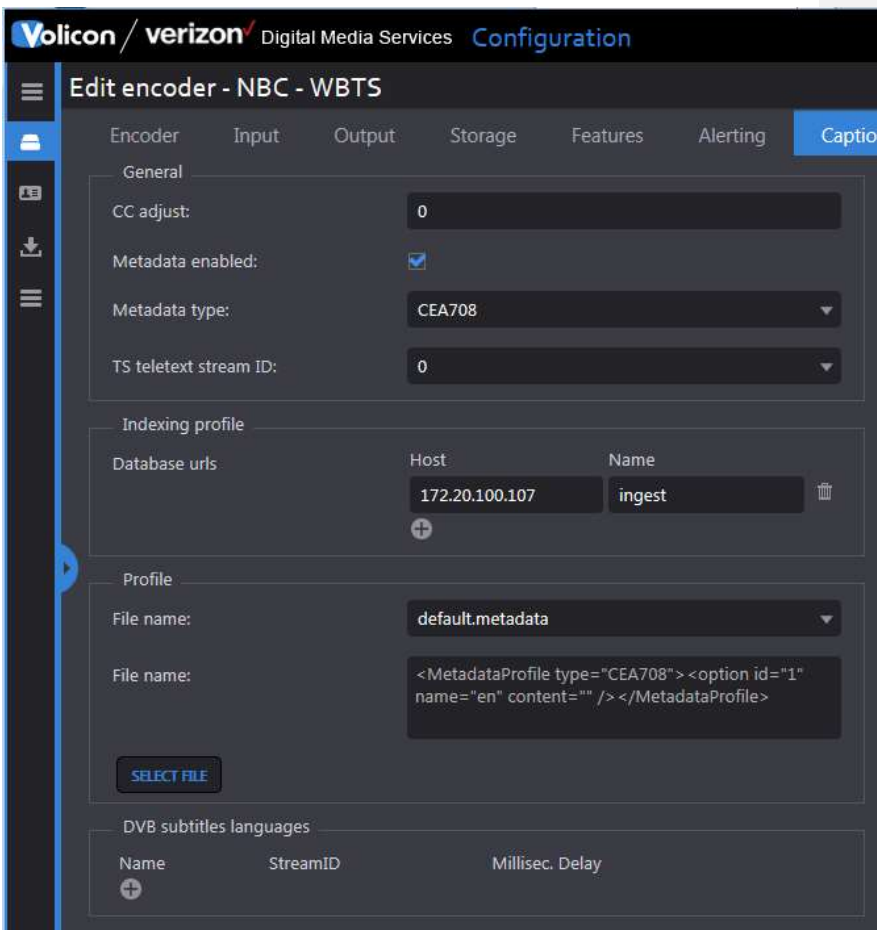

Figure: Encoder captions



<b>CC adjust</b>	Not currently relevant to Volicon Media Intelligence service
<b>Metadata enabled</b>	Enable/disable CC monitor
<b>Metadata type</b>	Dropdown used to specify which data the format channel is using
<b>TS teletext stream ID</b>	The ID of the teletext stream inside the Transport Stream program

Table: Closed captioning

<b>Database URLs</b>	Host and profile name
<b>Add/delete</b>	Add or remove metadata database URLs

Table: Indexing profile

<b>File name</b>	Database name; <b>&lt;Select file&gt;</b> to add additional profiles
------------------	--

Table: Profile

<b>Name</b>	Name of the language
<b>StreamID</b>	Stream ID of the subtitle language
<b>Milliseconds delay</b>	The delay of subtitles in relation to the video; used to synchronize subtitles to video
<b>Add/delete</b>	To add/remove subtitle language

Table: DvB subtitles language

### 11.2.8.10 Encoder: More

This section configures Volicon Media Intelligence service to recover from encoder errors and sets encoder hibernation time.

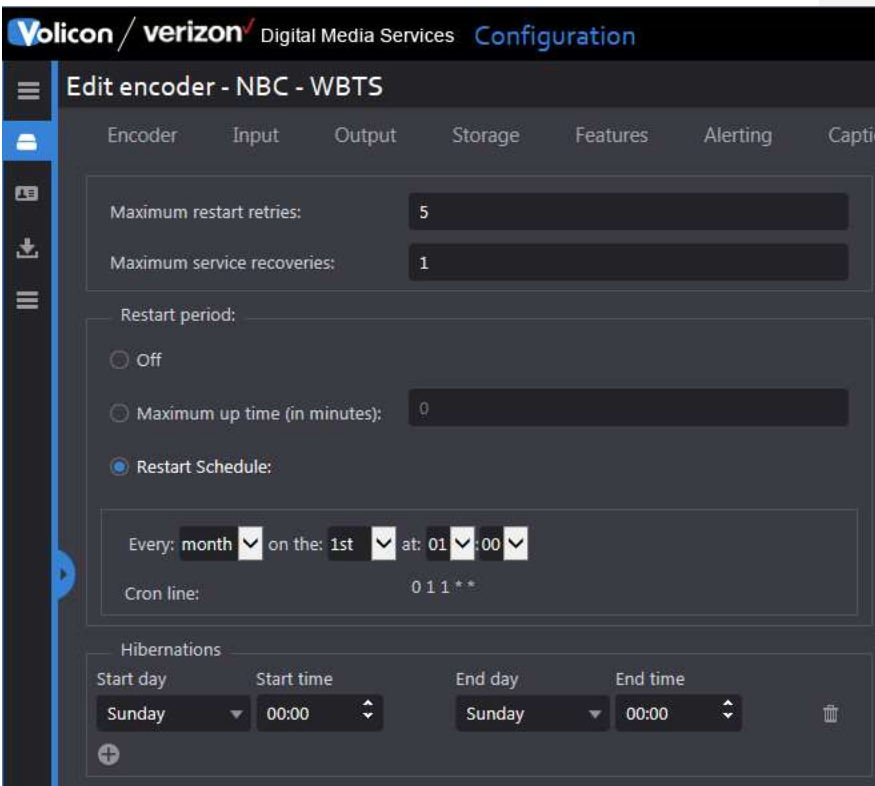

Figure: Encoder – more section

<b>Maximum restart retries</b>	The maximum number of times the watchdog will attempt to restart the encoder
<b>Maximum service recoveries</b>	The maximum number of times the watchdog is allowed to restart the entire service

Table: Error recovery

The restart period can be used to force the encoder to restart based on uptime or a specific date and time.

<b>Off</b>	No force restart
<b>Maximum up time</b>	Restarts encoder when elapsed run-time exceeded
<b>Restart schedule</b>	Forces restart at specific date and time
<b>Cron line</b>	Selected schedule in Cron format

Table: Restart period

<b>Start</b>	Hibernation start day/time
<b>End</b>	Exit hibernation day/time
<b>Add/delete</b>	Add and remove hibernation events

Table: Hibernation

### 11.3 Configuration: Probe profiles

The proposed feature is not yet implemented.

### 11.4 Configuration: Encoder profiles

The proposed feature is not yet implemented.

### 11.5 Configuration: Manage streams

The proposed feature is not yet implemented.

### 11.6 Settings: Central server

The settings section is used to configure central server behavior: channels, profiles, user accounts, etcetera.

This section is broken down into six subsections:

- **System:** Configure overall settings
- **SNMP receivers:** Configure listening ports to receive SNMP messages
- **Channel set:** Logical channel grouping independent of physical encoder
- **Distribution profiles:** Specify how clips exported
- **Roles:** Specify which aspects of Volicon Media Intelligence service each user role is able to access
- **Users:** Contain list of all user accounts

## 11.6.1 System

Use this page to configure system-wide global settings.

### 11.6.1.1 System: General

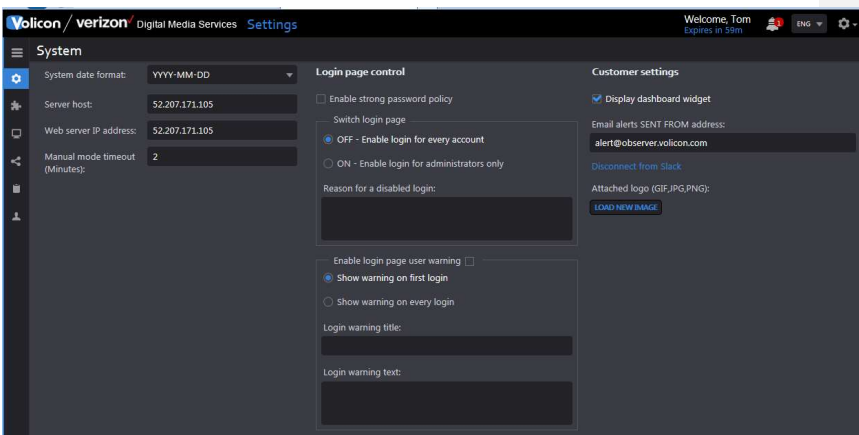

Figure: System general

<b>System date</b>	Dropdown used to select desired year-month-day format
<b>Server host</b>	Central server IP address on LAN
<b>Web server IP address</b>	Central server web IP address
<b>Manual mode timeout</b>	Not yet implemented; will allow UIRT remote control of STB
<b>Enable strong password policy</b>	Requires users to periodically reset passphrase and use combination of characters to create strong passwords; system will refuse to accept passphrase change if doesn't meet requirements and will prompt user with requirements; criterion for password acceptance: A minimum of eight characters One uppercase letter One lowercase letter One number One symbol character NO REPEATING characters

<b>Switch login page</b>	Allows you to substitute a different welcome page when user access is disabled
<b>Enable login for every account</b>	Normal login page from which all users are able to access the system
<b>Enable login for administrators only</b>	Displays alternative login page when user attempts to log in to system; does not affect administrator account
<b>Reason to disable login</b>	Text message displayed when users prevented from accessing system (“ <i>System maintenance underway – system will be back online by 5AM Tuesday.</i> ”)
<b>Enable login page user warning</b>	Allows you to display a warning message when user logs in; can be set to occur on first login or every login
<b>Login warning title</b>	Message title
<b>Login warning text</b>	Warning text
<b>Display dashboard widget</b>	Adds  alerts icon at the top-right of each page; indicates the number of active faults; clicking icon provides details about each fault
<b>Email alerts sent address</b>	Email address used to send email alerts from central server
<b>Disconnect from Slack</b>	Ability to send QoE alerts via Slack; may be enabled/disabled – not relevant to all implementations
<b>Attached logo</b>	Attach company logo to the alert email; permissible file types: JPG, GIF, PNG

Table: Central server – general settings

## 11.6.2 Settings: SNMP receivers

This section configures Volicon Media Intelligence service to accept polling requests from the Network Management Systems (NMS). The Volicon Media Intelligence service SNMP implementation is read-only. The management console is able to query Volicon Media Intelligence service for status but not change settings via SNMP. Volicon Media Intelligence service issues traps reporting unusual events to the management console.

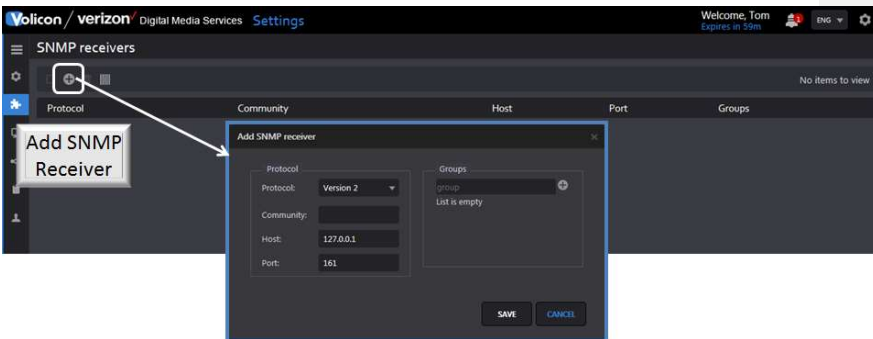

Figure: SNMP receivers

<b>Protocol</b>	Enter the version your NMS uses. Volicon Media Intelligence service supports SNMP v1 and SNMP v2.
<b>Community</b>	Public by default (unrestricted access), a password is required to establish connectivity with the SNMP receiver.
<b>Host</b>	This is the URL or IP of the destination where the trap is to be sent. Set it to localhost if all requests originate on the same machine as CS.
<b>Port</b>	Enter the port used for SNMP traffic with the host. A well-known SNMP is port 162.
<b>Groups</b>	This is a list of active directory groups.

Table: SNMP receiver settings

### 11.6.2.1 Add/edit SNMP receiver settings

To create a new **SNMP receiver**, click the **<Add>** button at the top of the page. To edit an existing receiver, hover over the receiver name and right click on the **<Edit>** icon on the right-hand side. Enter the appropriate values and press **<Save>**.

### 11.6.3 Settings: Channel set

This page is used to define channel sets. Using channel sets enables the administrator to create a logical channel grouping independent of the probes in which the specific encoder is located. If channel sets are not used, individual encoders are displayed under their associated probe.

### 11.6.3.1 Add/edit channel set

To add a channel set, click the **<Add new channel set>** icon at the top of the page. If your system has a large number of encoders, use the “Encoder filter” field to restrict which encoders are displayed. To edit an existing channel set, hover over the channel set and click the **<Edit>** icon. Enter or change the name of the channel set and select the desired encoders. Press **<Save>** when you are finished.

**Example:** “AJN” is set, which includes four encoders from probe DEMO-TS and six encoders from probe WIN7. The number of encoders assigned to a specific channel set is displayed in parenthesis to the right of the set name.

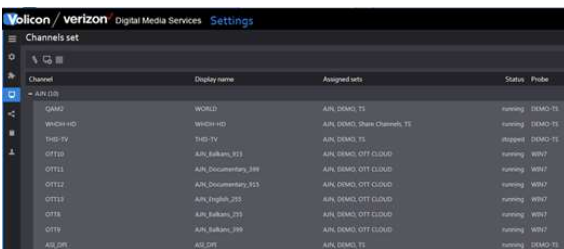

Channel	Display name	Assigned sets	Status	Probe
- AJN (38)				
QAM2	WORLD	AJN, DEMO, TS	running	DEMO-TS
WCHD-HD	WCHD-HD	AJN, DEMO, Shark Channels, TE	running	DEMO-TS
THD-TV	THD-TV	AJN, DEMO, TS	stopped	DEMO-TS
OTT01	AJN_Balaban_013	AJN, DEMO, OTT CLOUD	running	WIN7
OTT02	AJN_Documentary_098	AJN, DEMO, OTT CLOUD	running	WIN7
OTT03	AJN_Documentary_013	AJN, DEMO, OTT CLOUD	running	WIN7
OTT04	AJN_English_015	AJN, DEMO, OTT CLOUD	running	WIN7
OTT05	AJN_Balaban_015	AJN, DEMO, OTT CLOUD	running	WIN7
OTT06	AJN_Balaban_098	AJN, DEMO, OTT CLOUD	running	WIN7
OTT07	AJN_098	AJN, DEMO, OTT CLOUD	running	WIN7
OTT08	AJN_098	AJN, DEMO, TS	running	DEMO-TS

Figure: Settings channel set

### 11.6.3.2 Delete a channel set

Hover over the desired channel set and press the **<Trash>** icon.

### 11.6.4 Distribution profiles

The distribution profiles specify how clips exit the Volicon Media Intelligence service environment. “Export” defines what data is included (e.g., audio language, video resolution and metadata). Export settings apply to both saving clips on the user’s workstation and publishing them to remote sites. Publishing requires two additional profiles: destination and publish. The destination profile defines social media destinations where the clips will be sent along with any necessary account credentials. The publish profile defines in what format the clip should be encoded and specifies one or more previously defined destinations.

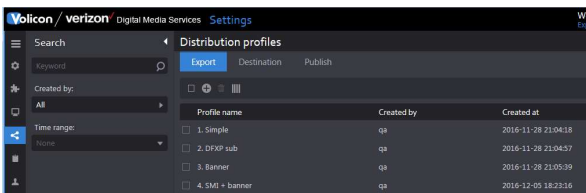

Profile name	Created by	Created at
<input type="checkbox"/> 1. Simple	qa	2016-11-28 21:04:18
<input type="checkbox"/> 2. DFXP sub	qa	2016-11-28 21:04:57
<input type="checkbox"/> 3. Banner	qa	2016-11-28 21:05:39
<input type="checkbox"/> 4. SMI + banner	qa	2016-12-05 18:23:16

Figure: Settings distribution profiles

### 11.6.4.1 Export

To create a new export profile, click the **<Add>** icon at the top of the page. To edit an existing profile, hover over the profile name and click the **<Edit>** icon at the far right.

The video profile opens on the right side of the page. To select a new profile, use the **<Choose an encoder as profile base>** dropdown. This sets the rest of the page defaults based on the configuration of the specific encoder. Once the profile is updated, type the name into the profile name line. This is the name that will be displayed.

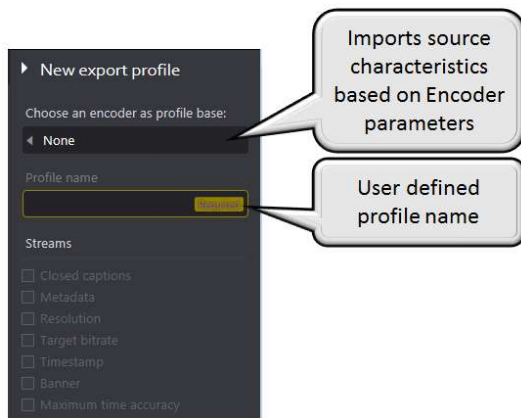

Figure: Export profile, part 1

The streams setting allows you to select video and (one or more) audio channels. You are able to restrict the export to solely audio or video if desired. If the stream is being captured by Volicon Media Intelligence service in more than one video resolution and frame rate, use the dropdown to select the version you want to use as the source of the export.

Closed captions enables CC – if you try to select this option and the encoder does not support CC, an error message appears at the top of the screen. Select the CC language if more than one exists. The default setting “Burn to video” includes the CC as part of the video clip. The other option, “Export to file”, saves only the CC portion in the file type specified. If you select “Export to file”, use the associated dropdown to select the file type to save the CC. Use “Adjust xx seconds” to adjust CC time in seconds so it will fit the video.

When metadata is checked and metadata is included in the clip, it will be exported with the clip; otherwise, it is suppressed. Use the radio button to select which metadata to include.



Resolution and target bitrate allow you to export the output clip in a different resolution and bitrate than it was injected by Volicon Media Intelligence service. Set both parameters using the drop-down menus. Volicon Media Intelligence service will then transcode the stream to these settings prior to export.

Timestamp defaults to the central server time zone (auto). If you want to use a different time zone, select **<Other>** and use the dropdown to select offset from UTC. Use the **<Format>** option to delete unnecessary timestamp fields.

The banner allows you to superimpose an image from your workstation. The permissible file formats are JPG, PNG, GIF, TIF, BMP and WEBP. The Volicon Media Intelligence service controls allow flexible placement, size and degree of transparency.

Maximum time accuracy provides frame-by-frame timing accuracy.

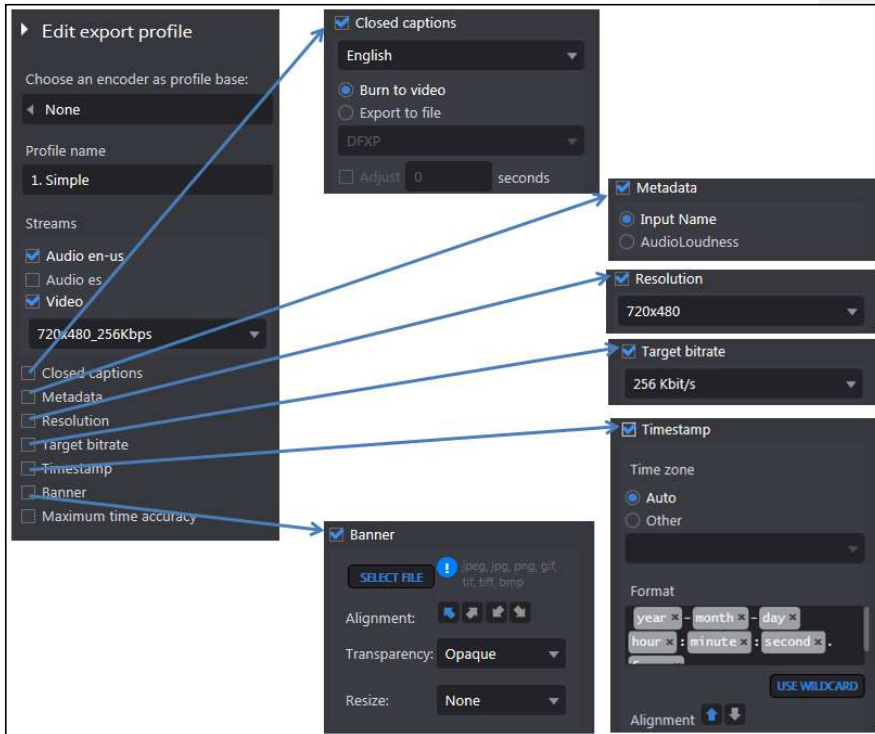

Figure: Export profile, part 2

### 11.6.4.2 Destination

To create a new destination, click the **<Add>** icon at the top of the page. To edit an existing destination, hover over the destination name and click the **<Edit>** icon at the far right.

If the new destination is similar to an existing one, hover over the existing destination and press the **<Duplicate>** icon located at the far right of the destination field. The system will duplicate the destination and add a numeric identifier – (1) for the first duplicate, (2) for second and so on. Then use the **<Edit>** function to make changes.

To delete a destination, hover over the name and press the **<Delete>** icon. If you want to remove multiple destinations, check the ones to delete and use the **<Delete>** icon in the middle of the page.

A list of available destinations appears in the right-side pane. Click on the desired destination. A new panel will open asking for additional information. In some cases, you will need to log in to the remote site and manually fill out some of the text fields. The account name you used to log in will be automatically displayed to the right of the destination name. This allows you to create multiple destination profiles going to the same social media site.

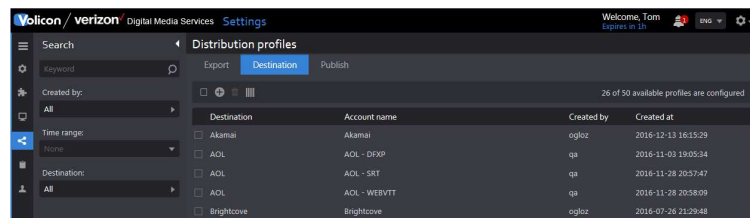

Figure: Settings distribution profiles

### 11.6.4.3 Publish profile

To create a new publish profile, click the **<Add>** icon at the top of the page. To edit an existing profile, hover over the profile name and click the **<Edit>** icon at the far right. Once this is complete, it is possible to publish video clips to multiple destinations simultaneously.

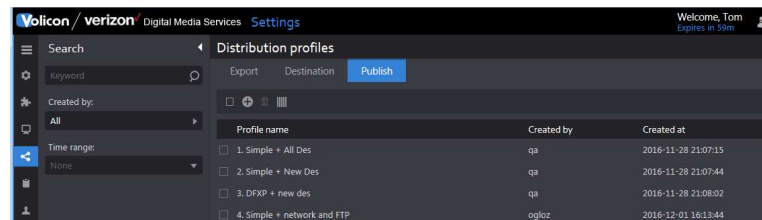

Figure: Settings publish profile

---

A new page pops up with four sections:

<b>Profile name</b>	Type the new name or edit the old one.
<b>Video export profiles</b>	Check one of the existing export profiles. The export profile specifies if output is audio/video or both and configures various video options. If none of the existing export profiles is appropriate, you need to create a new one.
<b>Transcoding commands</b>	Select one of the transcoding options if you want to use a compression scheme rather than the one specified in the export profile.
<b>Destination</b>	Select one or more of the previously configured destination profiles.

Table. Publish profile

### 11.6.5 Roles

This section enables you to create named roles with specific access permissions. When an account is generated, it is associated with one or more role. The administrator account is unique in that it has permissions to all Volicon Media Intelligence service features and cannot be deleted.

<b>Applications</b>	Applications grant the user access to Share, Deliver, Review, Comply, Monitor and admin screens.  Checking the top-level function automatically selects all features for that function. If you want to restrict access to a subset, uncheck specific features.
<b>Permissions</b>	This defines how the role is able to utilize Volicon Media Intelligence service.
<b>Channels</b>	This sets which channels are accessible by the role. Each entry consists of one or more channel set.
<b>Users</b>	This displays all user accounts associated with the role.
<b>Defaults</b>	This sets the session timeout and maximum number of concurrent videos.
<b>Publish profile</b>	This selects the social media each role is able to export.

Table: Roles

To add a new role, click the **<Add>** icon at the top of the dashboard. This opens an empty role. Since roles can be complex, and often there are only small differences between roles, use the **<Duplicate>** feature to simplify the task. Highlight an existing role that is as similar to the new one as possible, then click on the **<Duplicate>** icon. Type in the new name and click **<OK>**. Then access that role and make any necessary changes.

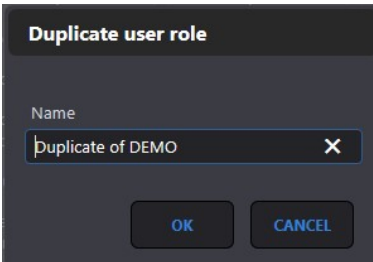

Figure: Creating a duplicate role

### 11.6.5.1 Applications

For the remainder of this section, we will be using the user's role as an example. The same rules apply to any named role.

Example: Looking at the user's role, we note it allows access to all Volicon Media Intelligence service features except admin screens.

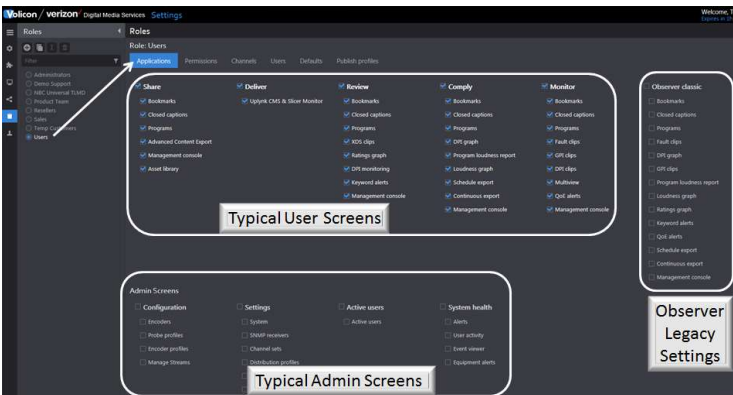

Figure: Settings – roles

### 11.6.5.2 Permissions

This section defines, in great granularity, how each role is able to utilize Volicon Media Intelligence service.

<b>Clips</b>	Determines if user is able to create, edit and delete bookmarks
<b>Programs</b>	Determines if user is able to create, edit and delete programs
<b>Mobile</b>	Normal Volicon Media Intelligence service access from fixed workstation; allows access from smartphones
<b>Share – clip</b>	Sets the maximum clip length and number of clips shared per day
<b>Ad-hoc share</b>	
<b>Advanced share</b>	
<b>Share – management console administrator</b>	
<b>Share light editor</b>	Enables limited video editing to bookmarks
<b>Export</b>	Specifies which browsers are able to export and whether or not a program ingested as a Transport Stream can be exported

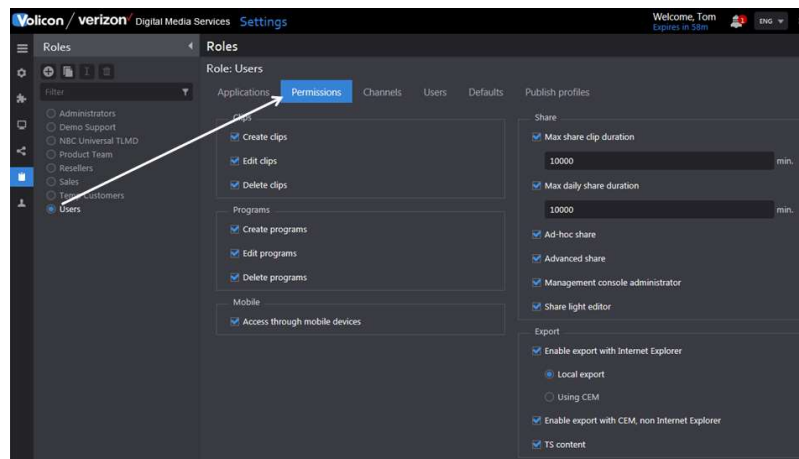

Figure: Role – permissions

### 11.6.5.3 Channels

This section defines the channel sets each role is able to access. To add a channel set to a role, click the **<Add>** icon at the top of the middle section of the page. A list of previously defined channel sets is displayed on the right of the page. Using channel sets allows you to logically group associated channels regardless of how and where they are ingested into Volicon Media Intelligence service.

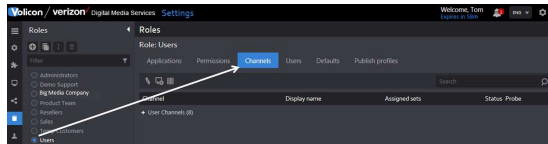

Figure: Role – channels

### 11.6.5.4 Users

This page lists all users assigned to the specified role. An account may be assigned to more than one role. To add an account to the role, click the **<Add new user>** icon at the top of the middle section. A list of all account names appears in the right-hand pane. If the list is lengthy, use the **<Filter>** option at the top to limit the display to matching search criteria.

To remove an account from the role, hover over the account name. The name is highlighted in blue. Click on the **<Delete>** icon at the right to remove the account.

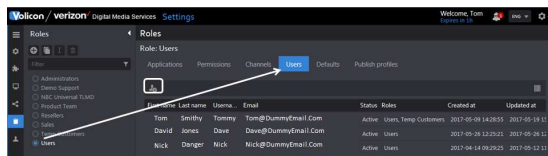

Figure: Role – users assigned

### 11.6.5.5 Defaults

This section specifies common behavior for the role.

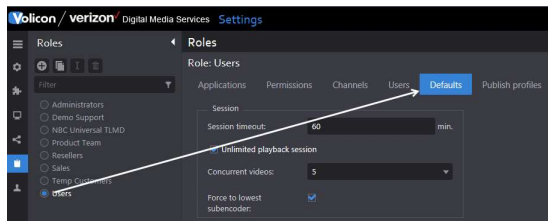

Figure: Role – defaults

<b>Session timeout</b>	Idle timeout; user will be automatically logged out of the system
<b>Unlimited playback session</b>	Inhibits automatic inactivity timeout when playing a video
<b>Concurrent videos</b>	Maximum number of simultaneous videos a role is able to play; value set via dropdown
<b>Force to lowest sub-encoder</b>	If checked, and program ingested in multiple resolutions/bitrates, then lowest resolution/bitrate used

### 11.6.5.6 Publish profiles

This section assigns a distribution profile to the role. This allows accounts assigned to the role to export clips to all destinations defined in the distribution profile. Use the **<Add>** icon to add additional distribution profiles to the role, or hover over the profile name and click **<Delete>** to remove it from the role.

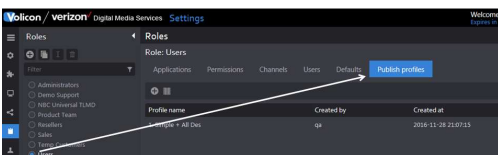

Figure: Role – publish profiles

### 11.6.6 Users

This page displays all **user** accounts. If your system has a large number of users, use the dashboard search feature to restrict how many accounts are displayed. The admin account is built into Volicon Media Intelligence service and cannot be deleted.

Accounts are in either active or inactive status. Active accounts are able to log in, whereas inactive accounts are not. This allows the administrator to temporarily restrict access without having to delete the account.

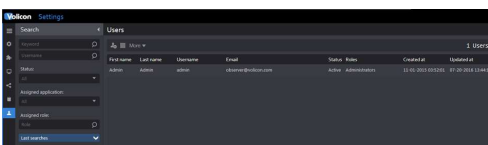

Figure: Settings – users

### 11.6.6.1 Adding/modifying account

Click **<Add new user>** to create a new account, or hover over an existing account and press the **<Edit>** icon at the extreme right of the entry. The “Edit user” panel at the right of the page lets you modify account features. The **<Roles>** drop-down section (toward the bottom of the page) allows you to specify which aspects of Volicon Media Intelligence service the account is able to access.

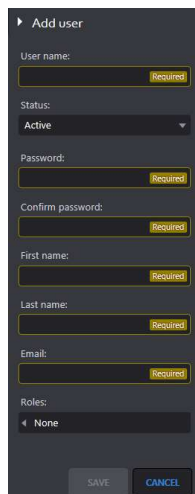

Figure: Add new user

### 11.6.6.2 Change password

From time to time, it may be necessary for the Volicon Media Intelligence service administrator to change a user’s password. Use the **<Edit>** feature and enter the new password twice.

### 11.6.6.3 Suspend account

If you need to temporarily prevent a user from accessing Volicon Media Intelligence service, use the **<Edit>** feature to change the status from active to inactive. This prevents the user from logging into the system, but it does not delete the account.

### 11.6.6.4 Delete account

To delete an account, hover over the name and click on the **<Trash>** icon at the extreme right of the account name.



### 11.6.6.5 Export user account list

Volicon Media Intelligence service allows you to create an Excel spreadsheet of user accounts. Click the  **<Export>** icon at the top of the page. A status message at the top of the screen indicates the file is being created and when it is ready to export. When the file is ready, a dialog box opens, allowing you to view it or save to your workstation.

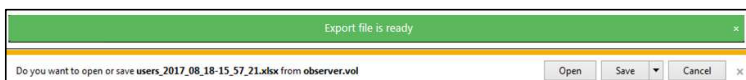



Figure: Export account list

## 11.7 Active users

This page displays a list of currently logged in users and provides a method to disconnect individual users.

The screenshot shows all possible columnar information. Use this  icon to enable/disable which columns Volicon Media Intelligence service displays. Volicon Media Intelligence service automatically logs out inactive users. The far right-hand column indicates how much time is left until forced logout. The timeout value is configured for each role via **<Settings>** → **<Role>** → **<Defaults>** → **<Session>**, so you can set different times depending on the role.

First name	Last name	Username	IP	User agent	Expires after
Darren	Lejke	Darren.	10.10.100.145	Mozilla/5.0 (Macintosh; Intel Mac OS X 10_11_0) AppleWebKit/...	00:30:00
Tom	Scheidt	tscheid2	192.168.2.100	Mozilla/5.0 (Windows NT 6.1; WOW64; Trident/7.0; rv:11.0) like...	01:00:00

Figure: Active users

### 11.7.1 Force user logout

To force a user logout, hover over the account name and press the  **<Logout>** icon on the extreme right. The user is logged out and will need to log back in. If you want to prevent the user from logging back into Volicon Media Intelligence service, change the account status to inactive via the **<Setting>** → **<User>** section.

## 11.8 Preferences

This section allows you to customize the way Volicon Media Intelligence service displays information for your account.

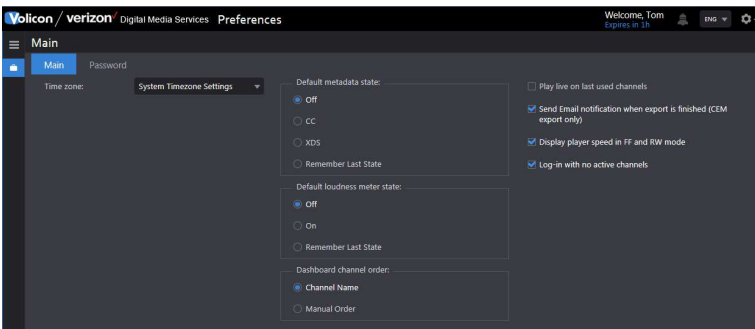

Figure: Preferences

## 11.8.1 Main

If you make changes to any of the main sections, press the **SAVE CHANGES** **<Save changes>** icon at the bottom of the page. If Volicon Media Intelligence service is able to successfully save your changes, it displays a banner at the top of the page.



Figure: Preferences successfully updated

### 11.8.1.1 Time zone

Volicon Media Intelligence service defaults to the same time zone as your computer. If you want to override that setting and select a different time zone, use the **<Time zone>** dropdown.

### 11.8.1.2 Default states

The default metadata state and default loudness meter state control viewer behavior. For example, if CC (closed captioning) is selected, and the channel is closed-captioned, it will be displayed by default whenever the channel is opened. To override the default behaviors, turn off CC.

The dashboard channel order allows you to customize how channels are displayed (future feature not yet implemented).

### 11.8.1.3 Other

When the option “Play live on last used channel” is checked, the channel viewer automatically plays the channel in real time.

---

When the option “Send email notification when export is finished” is checked, Volicon Media Intelligence service sends an email to the address associated with your login.

When this option is checked, the media player adds speed display in fast-forward and rewind.

When this option is checked, previously selected channels are deselected at each new login.

## 11.8.2 Passwords

Volicon Media Intelligence service allows users to change their own passwords.



Figure: Preferences password

The system requires the new password to be entered twice. If they do not match when you attempt to update your password, Volicon Media Intelligence service displays an error message, and your old password continues to be in force.

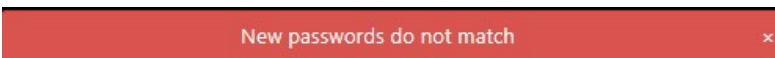

Figure: New passwords do not match

## 11.9 System health

System health is composed of three sections: Displays alerts, Users activity, and Event viewer. Each of the health sections has provisions to export the data to an Excel spreadsheet.

Development of this feature is still a work in progress.

## 11.9.1 Alerts

This section displays channel alerts. It can be rather lengthy, so use the dashboard **<Search>** feature to restrict the view to items of interest.

As with user accounts, the list may be exported to an Excel spreadsheet.

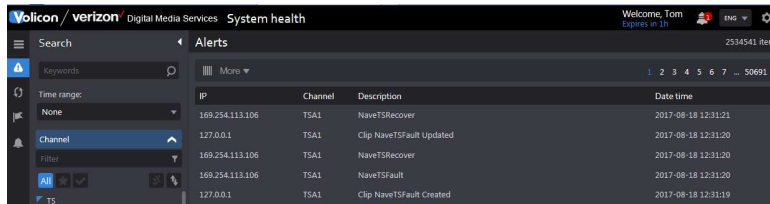

IP	Channel	Description	Date time
169.254.113.106	TSA1	NavetSRecover	2017-08-18 12:31:21
127.0.0.1	TSA1	Clip NavetSFault Updated	2017-08-18 12:31:20
169.254.113.106	TSA1	NavetSRecover	2017-08-18 12:31:20
169.254.113.106	TSA1	NavetSFault	2017-08-18 12:31:20
127.0.0.1	TSA1	Clip NavetSFault Created	2017-08-18 12:31:19

Figure: System alerts

## 11.9.2 User activity

This page displays all activity initiated by users like logging in and out and creating various clips. For purposes of this page, the system is considered a user, so system-initiated events are also displayed on this page.

The list may be exported as an Excel spreadsheet.

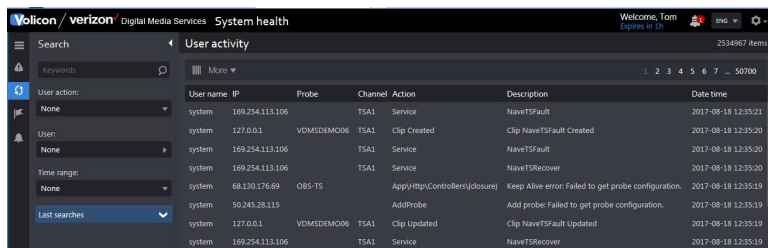

User name	IP	Probe	Channel	Action	Description	Date time
system	169.254.113.106		TSA1	Service	NavetSFault	2017-08-18 12:35:21
system	127.0.0.1	VOMSDemo06	TSA1	Clip Created	Clip NavetSFault Created	2017-08-18 12:35:20
system	169.254.113.106		TSA1	Service	NavetSFault	2017-08-18 12:35:20
system	169.254.113.106		TSA1	Service	NavetSRecover	2017-08-18 12:35:20
system	68.130.176.69	OBS-TS		App/Http/Controllers/closure	Keep Alive error: Failed to get probe configuration.	2017-08-18 12:35:19
system	59.245.28.115			AddProbe	Add probe: Failed to get probe configuration.	2017-08-18 12:35:19
system	127.0.0.1	VOMSDemo06	TSA1	Clip Updated	Clip NavetSFault Updated	2017-08-18 12:35:19
system	169.254.113.106		TSA1	Service	NavetSRecover	2017-08-18 12:35:19

Figure: User activity

### 11.9.3 Event viewer

This page displays internal system messages between the various Volicon Media Intelligence service subsystems.

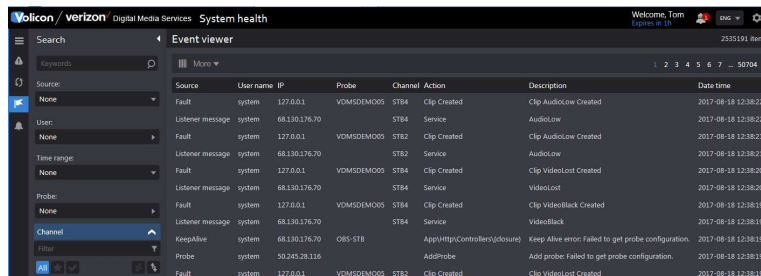

Figure: Event viewer

### 11.10 Help

Pressing <Help> displays numerous online tutorials. It also displays a link to Volicon Media Intelligence service customer service.

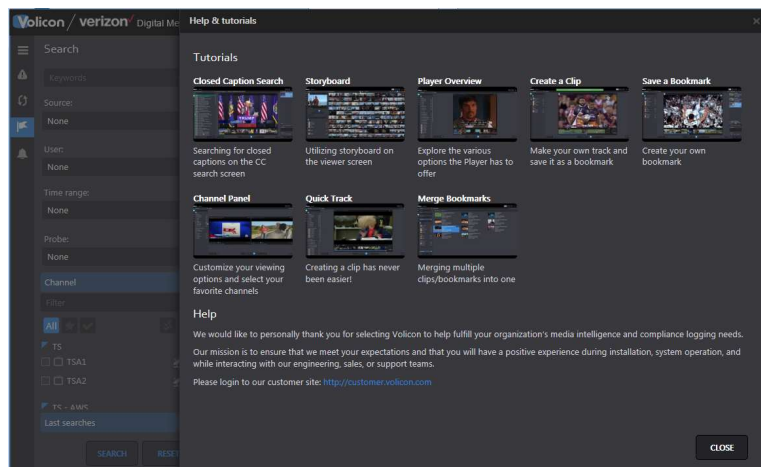

Figure: Customer Support help request

### 11.11 About

Press <About> to view Volicon Media Intelligence service software versions.

Each time a new version of the player is released, it is automatically pushed to end users if they are using Internet Explorer to access Volicon Media

---

Intelligence service. When first-time users log in after a new player is released, they are required to install it before using Volicon Media Intelligence service.

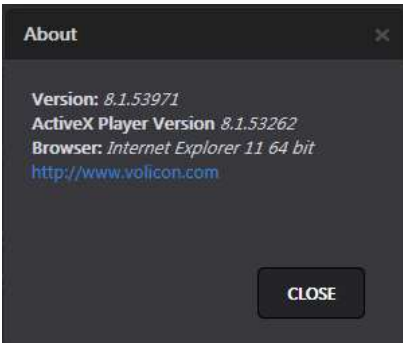

Figure: About display

## 11.12 Reset cache

Use the “Reset cache” option to clear all application caches, such as selected channels.

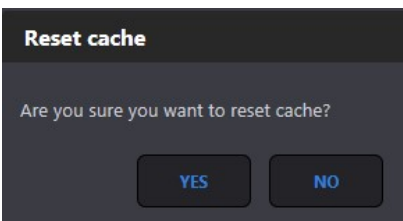

Figure: Reset cache

## 11.13 Log out

When you attempt to log out, you will be prompted to confirm the request as shown in the login section. If you have any unsaved changes, a warning message asks if you want to save them; otherwise, they will be lost. The same warning occurs whenever you attempt to change pages if there are unsaved changes on the page.

---

# 12 System monitoring procedure

The following system procedures are intended for system administrators as a guide to monitor the Volicon Media Intelligence service system health periodically. Network logging issues might result from a variety of causes (e.g., missing media streams, configuration issues, environmental changes or unexpected scenarios encountered by the system).

## 12.1 Checking probe status

Access the probe and encoder status by clicking **<Tools>** → **<Configuration>**, and select a **<Probe group>** to open the respective group page. The probe and encoder status is denoted by a color-coded icon to the left of the name.

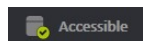

If the probe is accessible, the **<Status>** icon is green.

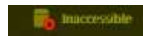

If not, it is red. Green simply indicates the probe server is accessible, not necessarily that all encoders are working normally. To check on individual encoders, expand the display to show encoders.

## 12.2 Encoder status

The encoder status is a green, red or amber ball to the left of the item name.

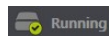

This indicates the probe or encoder is operating normally.



This indicates the probe or encoder has stopped and needs to restart.

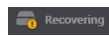

This indicates the probe or encoder is rebooting.

Hibernation means the probe is down as scheduled.

Dummy mode means the source is not available.

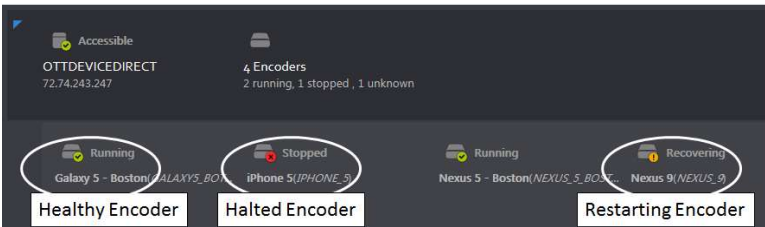

Figure: Group, probe and encoder status

### 12.2.1 Encoder fault corrective actions

If the issue is due to the source media not being present, try to resolve it with the responsible party. (Note the corresponding probe server name and address through **<Central config>** → **<Encoders>**).

Otherwise, if the encoder status is still red, it could be a stopped encoder. The probe must be restarted using the probe manager.

### 12.2.2 Monitor live media streams

To verify the encoder operation from the **<Configuration>** → **<Probe group>**, hover over the desired encoder and click **<Edit encoder>**. Press **<Preview player>** located in the diagnostic section. This opens a media player in live mode and will either display the stream or throw an error message at the top of the page.

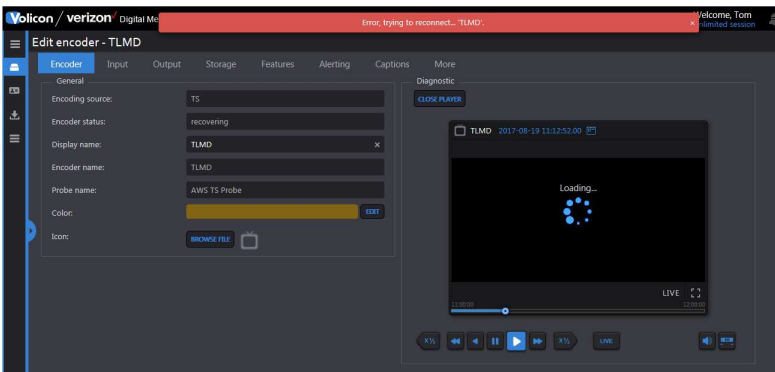

Figure: Encoder diagnostic



### 12.2.3 Checking memory and CPU utilization

To check memory and CPU utilization, log in to the server. Open the system “Task manager” by right clicking on the taskbar of a server desktop. Select the <Performance> tab and examine the “CPU usage” and the “physical memory” usage. These values should be under control, but if for some rare reason the CPU usage or memory usage is too high, contact Volicon Media Intelligence service Support to report it and request suggestions on how to proceed.

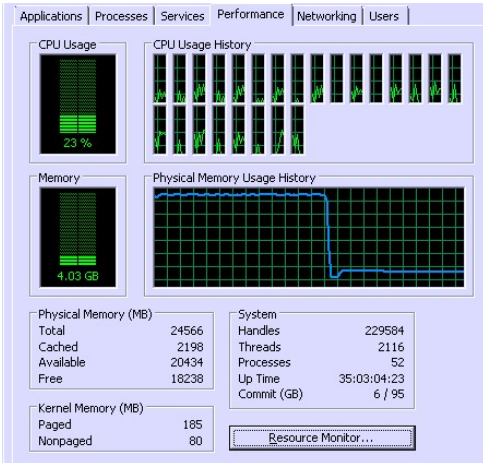

Figure: CPU and memory usage

### 12.3 Checking video storage utilization

Check the video storage utilization by right clicking on the <Mounted video> folder and selecting the “Properties” item from the popup menu. The “Video properties” window will appear.

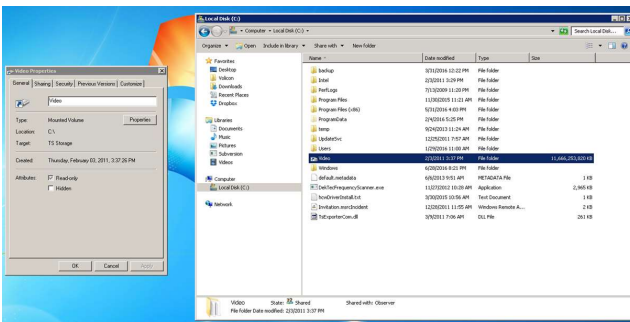

Figure: Select video properties

Click the <Properties> button to open the “(C:\Video) Properties” window as shown below. The <General> tab contains the video storage utilization pie

chart with “Used space” and capacity values. Their ratio, “Used space”/“Capacity”, yields the video storage utilization.

Insure this value levels off after reaching the specified Volicon Media Intelligence service storage capacity (e.g., six months of storage).

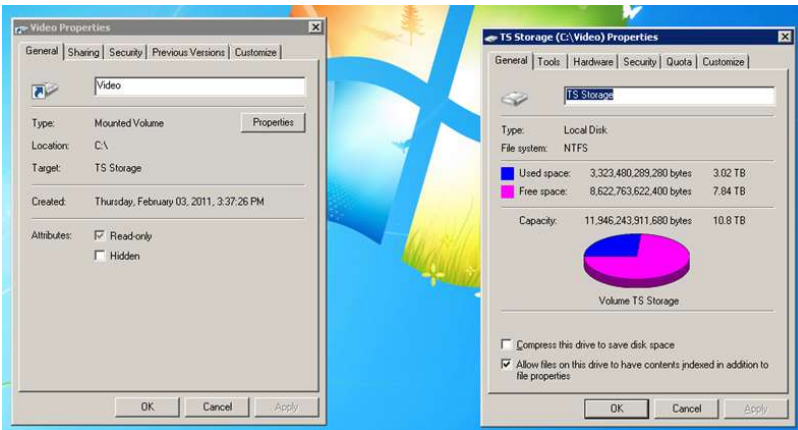

Figure: Video properties display

---

# 13

## Troubleshooting and maintenance

Troubleshooting often works best using the split-half method. Find a logical partition and check if everything up to that point is working correctly.

### 13.1 No video playing

- Verify the encoder's hostname/IP address for each stream/channel.
- Verify accessibility to media streaming ports 5502 or 4504 and 8001.
- Use the configuration tool to verify the encoder is running.
- Verify if Volicon Media Intelligence service encoder and Volicon Media Intelligence service streamer services are running on the probe server.
- Use the video application suite to play videos outside the Volicon Media Intelligence service environment.

### 13.2 User login

One common issue in large organizations is that sometimes users cannot access the Volicon Media Intelligence service system transparently, and the username/password dialog pops up. This is caused when IE cannot correctly determine which web server is in the intranet security zone (i.e., accessed by IP). The solution is either to access the server by server name (FQDN) or to add the accessed web server to the trusted security zone in IE.

#### 13.2.1 Client machine not working

After an Volicon Media Intelligence service software upgrade, or when you notice inconsistent client behavior, Volicon Media Intelligence service recommends deleting the temporary internet files in the browser.

---

## 13.3 Install player CAB file

When a systems administrator needs to install the ActiveX media player on multiple machines, or the firewall blocks player download from the web server, it's more convenient to work with the installation CAB file. You can download the CAB file from the Volicon Media Intelligence service web server address:

<https://MIS-url-addresss/MIS.cab>.

When the download completes, double click on the CAB file and accept the player prompts to install the media player.

## 13.4 License problem sources

To keep the Volicon Media Intelligence service license valid, avoid the following changes to the Volicon Media Intelligence service system:

- Enabling/disabling or changing any onboard hardware devices since license was applied
- Installing any additional hardware or software components

## 13.5 Capture card debugging

A useful troubleshooting method for investigating audio/video capture problems is to access the card directly from the card's application suite. This enables you to access the capture card without using Volicon Media Intelligence service.

### 13.5.1 Blackmagic

To verify a proper operation, connect the video source to the capture card. Launch Blackmagic Media Express and click on the **<Log and capture>** tab. Assuming everything is working correctly, the source will appear in the Media Express preview pane.



Figure: Capture preview



## 13.5.2 DekTec

### 13.5.3 Osprey

On the Osprey 460e cards, audio/video (A/V) can be examined at the input independently of the Volicon Media Intelligence service software. This is useful for general A/V debugging and for audio configuration.

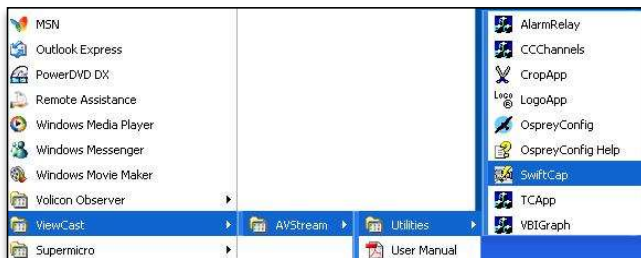

Figure: Accessing ViewCast

At the probe server, go to **<Programs>** and open the “ViewCast SwiftCap” program.

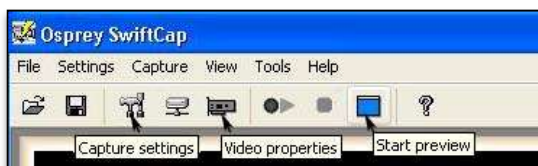

Figure: ViewCast SwiftCap

Select the video channels in “Capture settings”.

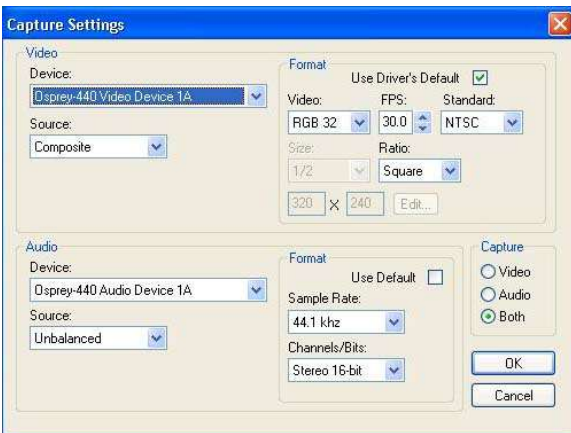
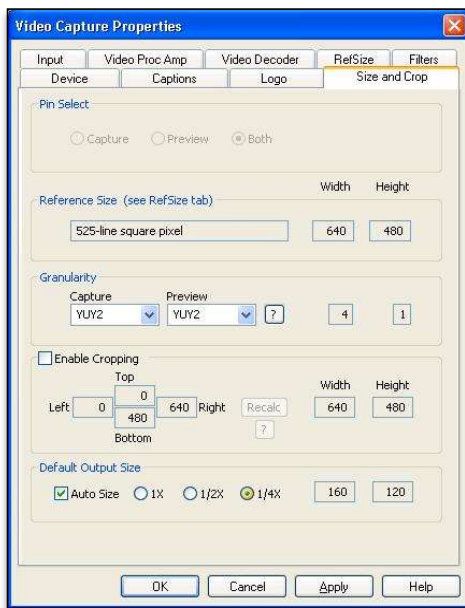

Figure: Select video channels

If you are working over Remote Desktop, and network bandwidth is limited, decrease the size of the SwiftCap display in "Video capture properties" by using the "Default output size" selection.

Click the **<Start review>** icon in the Osprey SwiftCap screen above to examine the video input you just configured.

### 13.5.3.1 Adjusting audio with Osprey encoder

In addition to the automatic audio adjustment, search for the “Audio adjust” section above; there is a manual procedure to adjust Osprey cards. From a desktop, select <Start> → <All Programs> → <ViewCast> → <AVStream> → <Utilities> → <OspreyConfig>.

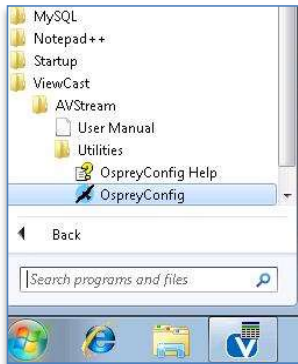

Figure: OspreyConfig

The OspreyConfig panel appears. Expand “Osprey-460e Device 1A” and select <Balanced Audio Filter> or <Unbalanced Audio filter>.

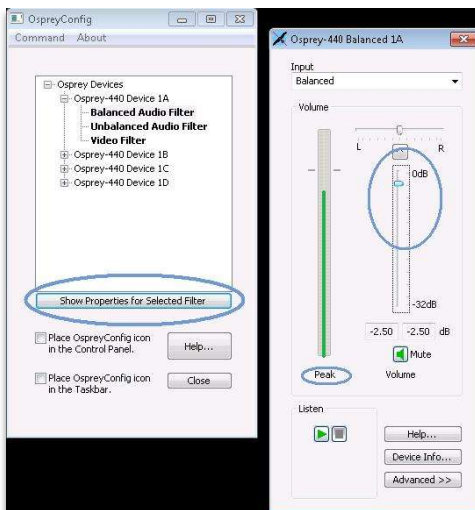

Figure: Osprey filter



---

Press the **<Show properties for selected filter>** button. The “Osprey 460e Balanced 1A” window will appear.

Note the “Peak” vertical (**green**) bar, which indicates the incoming signal level.

The volume bar on the right has a dB grading scale to measure the incoming signal. Move the “Audio gain” handle circled by the vertical ellipse accordingly to adjust the incoming audio level.

### 13.5.4 Hauppauge

Use the application suite to view input from the Hauppauge card.

## 13.6 Technical support portal

If you need support from Volicon Media Intelligence service, please fill out a request for service at our [Support](https://www.verizondigitalmedia.com/platform/volicon-media-intelligence/volicon-support/) web page: <https://www.verizondigitalmedia.com/platform/volicon-media-intelligence/volicon-support/>. In response, a case ticket number will be opened with a specific technician assigned to help with the issue. Then, every time you email or call back, please refer to your case ticket number until the case is closed.

# 14 SNMP notification

Volicon Media Intelligence service sends SNMP notifications to external systems (e.g., your Network Management System [NMS]) using the alert notification variables shown in the “SNMP notification settings” table. You must configure the IP addresses of your NMS stations in Volicon Media Intelligence service to enable this capability.

MIB definitions are common across all Volicon Media Intelligence service products.

## 14.1 MIB variables

SNMP V2 MIB variables, with definitions, are listed in the “EncoderTraps\_v2.mib” file or a similar \*.mib file located on the Volicon Media Intelligence service server in the “Program Files\Volicon\docs” directory. The MIB file should be used in addition to the “MIB variables” table below.

Commented [CHI]: Is this up-to-date?

The Volicon Media Intelligence service can send SNMP V2 trap messages both for media-related alerts that create fault clips and for system critical events that do not generate clips.

Alert variable names (in MIB)	OID Strings	Description
volEncoder	PREFIX = 1.3.6.1.4.1.23522.1	Probe server name, OID type and prefix for OIDs below
volEncoderName Octet String	PREFIX.2	Name of encoder that detected the alert; (names) configured during installation and usually not changed by the user
volEncoderHostname Octet String	PREFIX.3	Probe server hostname, IP or DNS name; unique hostnames required within servers on NMS monitored network
volAlertClipID Integer	PREFIX.11.1	Generated with each new event (e.g., media defect) to identify it
volAlertDescription Octet String	PREFIX.11.2	Textual description of the alert

<b>volAlertClipRef</b> Octet String	PREFIX.11.3	Alert clip ID and URL for its location on the web server (e.g., <a href="http://Volicon Media Intelligence service-url.com/clip_view.php?id=158079">http://Volicon Media Intelligence service-url.com/clip_view.php?id=158079</a> )
<b>volStreamName</b> Octet String	PREFIX.11.4	Stream/scanner name to help identify the link/STB location
<b>volAlertEnum</b> Integer	PREFIX.11.5	Grouping: event(0), test(10), service(20), encoder(30), storage(40), license(50), AFD fault(100), video(200), metadata(300), power(400), Video Lost(500)
<b>volAlertName</b> Octet String	PREFIX.11.6	E.g., AUDIOLOW, ENCODER STOPPED
<b>volAlertType</b> Integer	PREFIX.11.7	Signals the NMS SET(1) or CLEAR(0) alert states (e.g., alert is SET)
<b>volCertainty</b> Integer	PREFIX.11.8	Degree of alert type percentage (e.g., 96 percent of black screen)
<b>volAudioLevel</b> Integer	PREFIX.11.9	Integer value of audio Level in dB
<b>volAudioPin</b> Integer32	PREFIX.11.10	Audio Pin number – audio language pin; for now, single language used; Pin always 0
<b>volEventTime</b> Octet String	PREFIX.11.11	Time when the alert has occurred (e.g. 2010-10-31 20:57:21)
<b>rpmChannelID</b> Octet String	PREFIX.11.12	Channel number in the lineup; stored in a string (e.g., "124")
<b>rpmChannelName</b> Octet String	PREFIX.11.13	Lineup channel/service name (e.g., Fox)
<b>rpmChannelQAM</b> Octet String	PREFIX.11.14	Channel group name for any group of channels logically related
<b>volAlertSeverity</b> Integer32	PREFIX.11.15	Designates priority for a corresponding problem to get resolved: info(1), warning(2), minor(3), major(4), critical(5)
<b>oidAlertLevel</b> Octet String	PREFIX.11.16	Alert level (category) with one of the following possible values: probe (1), group (2), system (3)

<b>oidGroup</b> Octet String	PREFIX.11.17	Name of the affected probe group
<b>oidProbe</b> Octet String	PREFIX.11.18	Name of affected probe machine

Table: MIB variables

VolAlertName, volAlertEnum, and volAlertType variables indicate when to set or clear NMS internal alarms. System-related traps (other than for media), though not used to set or clear alarms, provide important information about the defect source, such as volAudioLevel and volAlertSeverity.

### 14.1.1 MIB variables alert example

A real-time trap from an audio alert was traced to build this table – specifically, the notification variables in the leftmost column. The last column illustrates examples to set and clear an SNMP alert.

Notification variables name	OID Strings	Description	Alert SET / CLEAR
<b>volEncoder</b>	PREFIX = 1.3.6.1.4.1.23522.1	Probe server name OID prefix for OIDs below	
<b>trapEncAlerts</b>	PREFIX.12 = 1.3.6.1.4.1.23522.1.12	ID identifying an Volicon Media Intelligence service trap; binds all other variables in it	
<b>volEncoderName</b>	PREFIX.2 = 1.3.6.1.4.1.23522.1.2 Octet String (Size 0...32)	Encoder stream name	<i>Value: ENC1</i>
<b>volEncoderHostname</b>	PREFIX.3 Octet String (Size 0...32)	Encoder hostname or IP address	<i>Value: ObsRpmVa</i>
<b>volEncAlerts</b>	PREFIX.11	Object identifier	
<b>volAlertClipID</b>	PREFIX.11.1 Integer32	Clip ID created on this alert	<i>Value: 6 (Value: 9)</i>

<b>volAlertDescription</b>	PREFIX.11.2 Octet String	Textual description of the alert	Value: LOW AUDIO LEVEL /(AUDIO-OK); History Channel 66; encoder: ENC1 Audio level: -69. (-34) Server time: 2010-09-29 18:52:41
<b>volAlertClipRef</b>	PREFIX.11.3 Octet String	URL to the clip created for this alert	Value: IP Address
<b>volStreamName</b>	PREFIX.11.4 Octet String (Size 0...32)	Stream (scanner in RPM) name	Value: P1
<b><u>volAlertEnum</u></b>	PREFIX.11.5 Integer [enumerate]	Alerts enumeration	See following table for "volAlertEnum"
<b><u>volAlertName</u></b>	PREFIX.11.6 Octet String (Size 32)	Alert nickname	<u>Value: AUDIOLOW</u>
<b><u>volAlertType</u></b>	PREFIX.11.7 Integer32 (0/1/2)	Type of alert: set(1), clear(0) or warning (2)	<u>Value: 1</u>
<b>volCertainty</b>	PREFIX.11.8 Integer32	Certainty in percentage	Value: 0
<b>volAudioLevel</b>	PREFIX.11.9 Integer32	Audio level in dB units	Value: -69 (-34)
<b>volAudioPin</b>	PREFIX.11.10 Integer32	Audio Pin	Value: 0
<b>volEventTime</b>	PREFIX.11.11 Octet String (Size 32)	Event time in format 2011/02/09 18:21:33	<i>Value: 2010-09-29 18:52:41</i>
<b>rpmChannelID</b>	PREFIX.11.12 Octet String (Size 32)	Lineup channel ID (usually a channel number)	Value: 66
<b>rpmChannelName</b>	PREFIX.11.13 Octet String	Lineup service name	Value: History Channel
<b>rpmChannelQAM</b>	PREFIX.11.14 Octet String (Size 32)	Lineup channel group	Value: Westside

<b>voAlertSeverity</b>	PREFIX.11.15 Integer{info (1), warning (2), minor (3), major (4), critical (5)}	The degree of priority to correct the problem	Value: 4
<b>oidAlertLevel</b>	PREFIX.11.16 Integer{probe (1), group (2), system (3)}	Alert level	
<b>oidGroup</b>	PREFIX.11.17 Octet String (32)	Name of affected probe group	Value: Burlington News
<b>oidProbe</b>	PREFIX.11.18 Octet String (32)	Name of affected probe server	Value: Probe66

Table: MIB variables alert example

## 14.2 SNMP notification signaling

Various alert-related SNMP traps are listed below.

<u>VoAlertName</u>	<u>Volicon Media Intelligence service RPM alerts (fault clips)</u> <u>Set/clear and notify (w/o clear) alerts</u>	<u>VoAlertEnum</u>
VIDEO-OK, AUDIOLOW	Set AUDIOLOW alert	<u>200</u> (VIDEO)
VIDEO-OK, AUDIOLOW	Clear AUDIOLOW event	<u>200</u>
VIDEO-OK, AUDIOHIGH	Set AUDIOHIGH alert	<u>200</u>
VIDEO-OK, AUDIOHIGH	Clear AUDIOHIGH alert	<u>200</u>
VIDEOLOST, AUDIOLOW	Set "video lost" alert	<u>500</u> (VIDEOLOST)
VIDEOLOST, AUDIOLOW	Clear "video lost" alert	<u>500</u>
VIDEOBLACK, AUDIOLOW	Set "video black" alert	<u>200</u> (VIDEO)
VIDEOBLACK, AUDIOLOW	Clear "video black" alert	<u>200</u>
VIDEOSTATIC, AUDIOLOW	Set "video static" alert	<u>200</u>
VIDEOSTATIC, AUDIOLOW	Clear "video static" alert	<u>200</u>
VIDEOMOTION	Set "video motion" alert	<u>200</u>
VIDEOMOTION	Clear "video motion" alert	<u>200</u>

<b>SCRIPTERROR</b>	System detected syntax error in the script	<u>200</u>
<b>CCLOST</b>	Set "closed captions lost" alert	<u>300</u> (METADATA)
<b>CCLOST</b>	Clear "closed captions lost" alert	<u>300</u>
<b>Equipment Error</b>	"Equipment error" event	
<b>STB Faulted</b>	"STB faulted" alert	
<b>NAVE-WM-FAULT</b>	Set "NAVE WM fault" alert	<u>50</u>
<b>NAVE-WM-RECOVERY</b>	Clear "NAVE low watermark" alarm	<u>50</u>
<b>NAVPERC-FAULT</b>	Set "NAVE percentage fault" alert	<u>60</u>
<b>NAVE-PERC-WARN</b>	Set "NAVE percentage warning" alarm	<u>60</u>
<b>NAVE-TS-FAULT</b>	Set "NAVE TS fault"	<u>70</u>
<b>NAVE-TS-RECOVERY</b>	Clear "NAVE TS fault"	<u>70</u>
<b>GPI FAULTS</b>	Set "GP faults" alert	<u>0</u>
<b>GPI FAULTS CLEAR</b>	Clear "GP faults" alert	<u>0</u>

Table: SNMP notification signaling

### 14.3 System alerts

Most of the equipment- and link-related alerts are detected at the probes and forwarded to the CS. The CS generates the event log and event viewer entries. Since these alerts do not generate SNMP traps, parameters like "AlertEnum" are not critical.

Alert name	<u>Description of Volicon Media Intelligence service events</u> <u>(No SNMP, only event log)</u>
Power	Toggle "STB Power" event
Test	"Test" event
Service stopped	"Service Stopped" event
Service started	"Service Started" alert
Probe down alert	"Probe down" alert
Probe recovered alert	"Probe recovered" alert
Encoder stopped	"Encoder stopped" alarm
Encoder started	"Encoder started " alert
AFD fault	"AFD fault" alert
Storage error	"Hard disk file error" event
License	"License expiration" event

T

TTTable: System alerts



---

# 15 Revision history

## 15.1 Volicon Media Intelligence service releases

Version	Build number	Date	Description

## 15.2 Revision change history

Date	Description